

# Parts Catalog

## Heat Shrink Tunnel



Phone (209) 985-8564

Houston Industries, LLC. PO Box 291 Sonoma CA 95476

# Table of Contents

Side Plate Assembly Diagram .....	4
Side Plate Assembly Parts List .....	5
Bearing Rail & Chain Guide Assembly Diagram .....	6
Bearing Rail & Chain Guide Assembly Parts List .....	7
Servo Drive Assembly Diagram .....	8
Servo Drive Assembly Parts List .....	9
Heater Drive Assembly Diagram .....	10
Heater Drive Assembly Parts List .....	11
Conveyor Drive Assembly Diagram (A) .....	12
Conveyor Drive Assembly Diagram (B) .....	13
Conveyor Drive Assembly Parts List .....	14
Conveyor Tensioner Assembly Diagram .....	15
Conveyor Tensioner Assembly Parts List .....	16
Side Plate Mounting Bars Diagram .....	17
Side Plate Mounting Bars Parts List .....	18
Bottom Heater, Duct & Vent Assembly Diagram .....	19
Bottom Heater, Duct & Vent Assembly Parts List .....	20
Bottom Heater, Duct & Vent Assembly Diagram .....	21
Bottom Heater, Duct & Vent Assembly Parts List .....	22
Bottom Blower Assembly Diagram .....	23
Bottom Blower Assembly Parts List .....	24
Hood & Guard Assembly Diagram .....	25
Hood & Guard Assembly Diagram .....	27
Control Panel Assembly Diagram .....	28
Control Panel Assembly Parts List .....	29
Transfer Roller Assembly Diagram .....	30
Transfer Roller Assembly Parts List .....	31
Bottom Trays & Covers Diagram .....	32
Bottom Trays & Covers Parts List .....	33
Package Guide & Sensors Diagram .....	34
Package Guide & Sensors Parts List .....	35
Shelf Covers & Mounting Feet Diagram .....	36

Shelf Covers & Mounting Feet Parts List.....	37
End Flap Blow Down Assembly Diagram .....	38
End Flap Blow Down Assembly Parts List .....	39
Heater Position Sensors Diagram.....	40
Heater Position Sensors Parts List.....	41
Flexible Wireway Diagram (A) .....	42
Flexible Wireway Diagram (B).....	43
Flexible Wireway Parts List.....	44
Height Adjustment & Casters Diagram.....	45
Height Adjustment & Casters Parts List.....	46
Low Voltage Diagram (A).....	47
Low Voltage Panel Diagram (B) .....	48
Low Voltage Panel Diagram (C) .....	49
Low Voltage Panel Parts List.....	50
High Voltage Diagram (A) .....	51
High Voltage Diagram (B).....	52
High Voltage Diagram (C).....	53
High Voltage Diagram (D) .....	54
High Voltage Parts List .....	55

# Side Plate Assembly Diagram

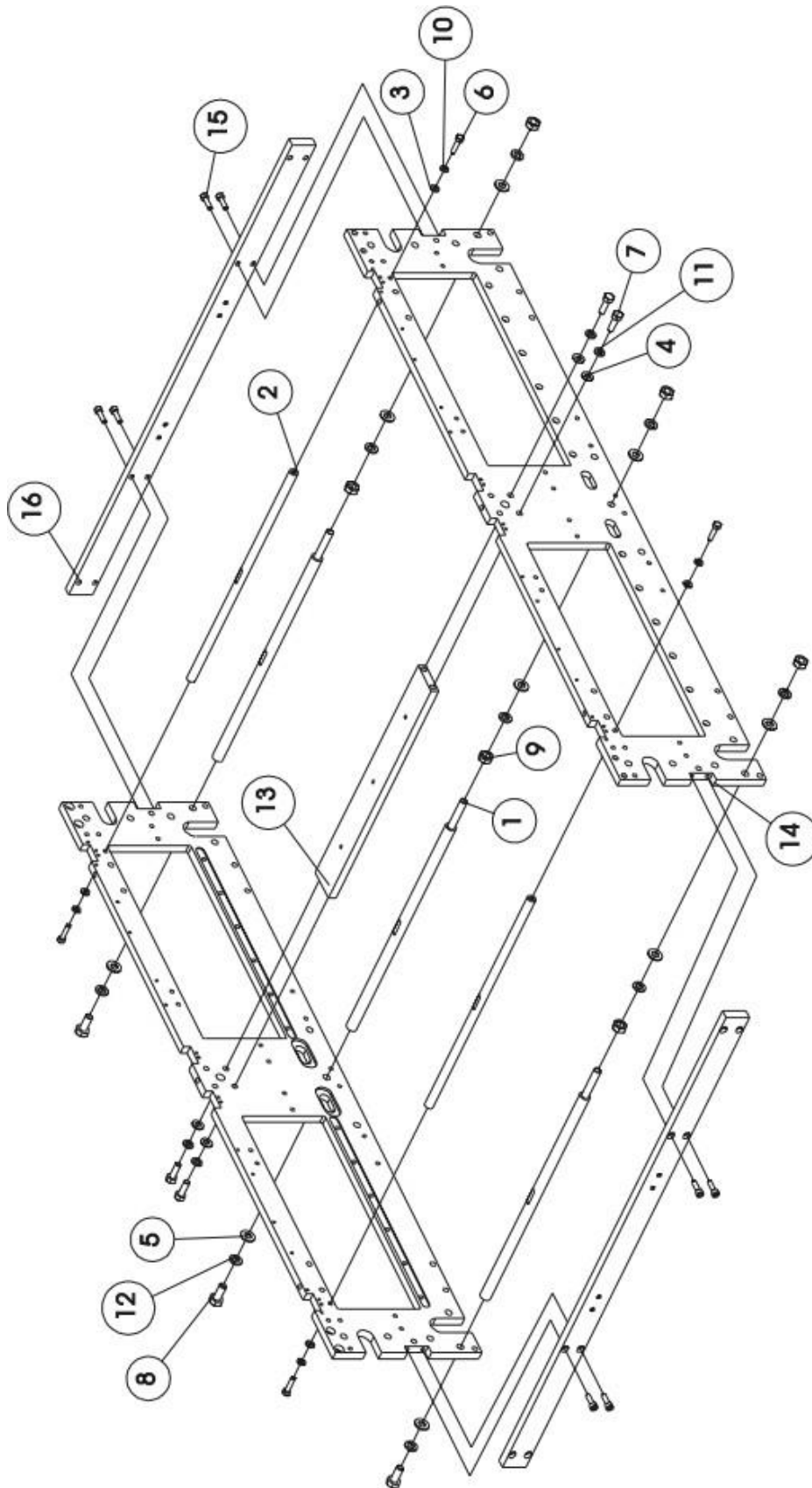

## Side Plate Assembly Parts List

Ref. No.	Part Description	Q'ty	Part No.	Part No. Factory Manual
1	Adjustable Brace	3	55KST-M1-1	032-0043
2	Brace	2	55KST-M1-2	032-0041
3	Flat Washer	4	55KST-M1-3	FW5606
4	Flat Washer	4	55KST-M1-4	FW5608
5	Flat Washer	9	55KST-M1-5	FW5610
6	Hex Head Cap Screw	4	55KST-M1-6	HH0625
7	Hex Head Cap Screw	4	55KST-M1-7	HH0825
8	Hex Head Cap Screw	3	55KST-M1-8	HH1025
9	Hex Nut	6	55KST-M1-9	HN5510
10	Lock Washer	4	55KST-M1-10	LW5706
11	Lock Washer	4	55KST-M1-11	LW5708
12	Lock Washer	9	55KST-M1-12	LW5710
13	Middle Brace	1	55KST-M1-13	032-0042
14	Side Plate	2	55KST-M1-14	032-0133
15	Socket Head Cap Screw	8	55KST-M1-15	SH0620
16	Tie Bar	2	55KST-M1-16	032-0117

# Bearing Rail & Chain Guide Assembly Diagram

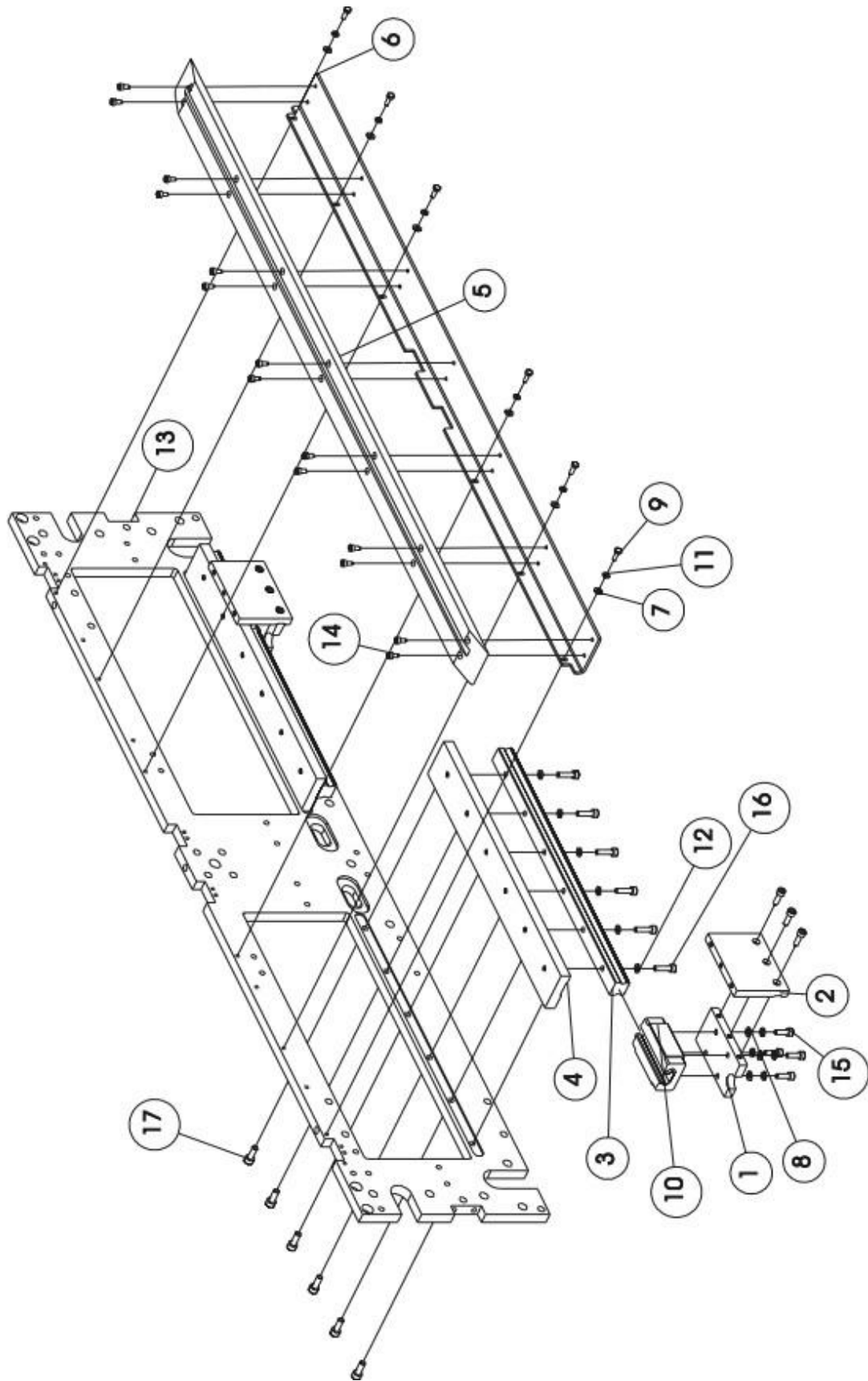

## Bearing Rail & Chain Guide Assembly Parts List

Ref. No.	Part Description	Q'ty	Part No.	Part No. Factory Manual
1	Bearing Plate	2	55KST-M2-1	032-0105
2	Bearing Plate Mount	2	55KST-M2-2	032-0106
3	Bearing Rail	2	55KST-M2-3	032-0092
4	Bearing Rail Mount	2	55KST-M2-4	032-0091
5	Chain Guide	1	55KST-M2-5	032-0094
6	Chain Guide Mount	1	55KST-M2-6	032-0093
7	Flat Washer	6	55KST-M2-7	FW5604
8	Flat Washer	8	55KST-M2-8	FW5605
9	Hex Head Cap Screw	6	55KST-M2-9	HH0412
10	Linear Bearing	2	55KST-M2-10	032-0196
11	Lock Washer	6	55KST-M2-11	LW5704
12	Lock Washer	20	55KST-M2-12	LW5705
13	Side Plate	1	55KST-M2-13	032-0133
14	Socket Head Cap Screw	14	55KST-M2-14	SH0408
15	Socket Head Cap Screw	14	55KST-M2-15	SH0516
16	Socket Head Cap Screw	12	55KST-M2-16	SH0520
17	Socket Head Cap Screw	12	55KST-M2-17	SH0616

# Servo Drive Assembly Diagram

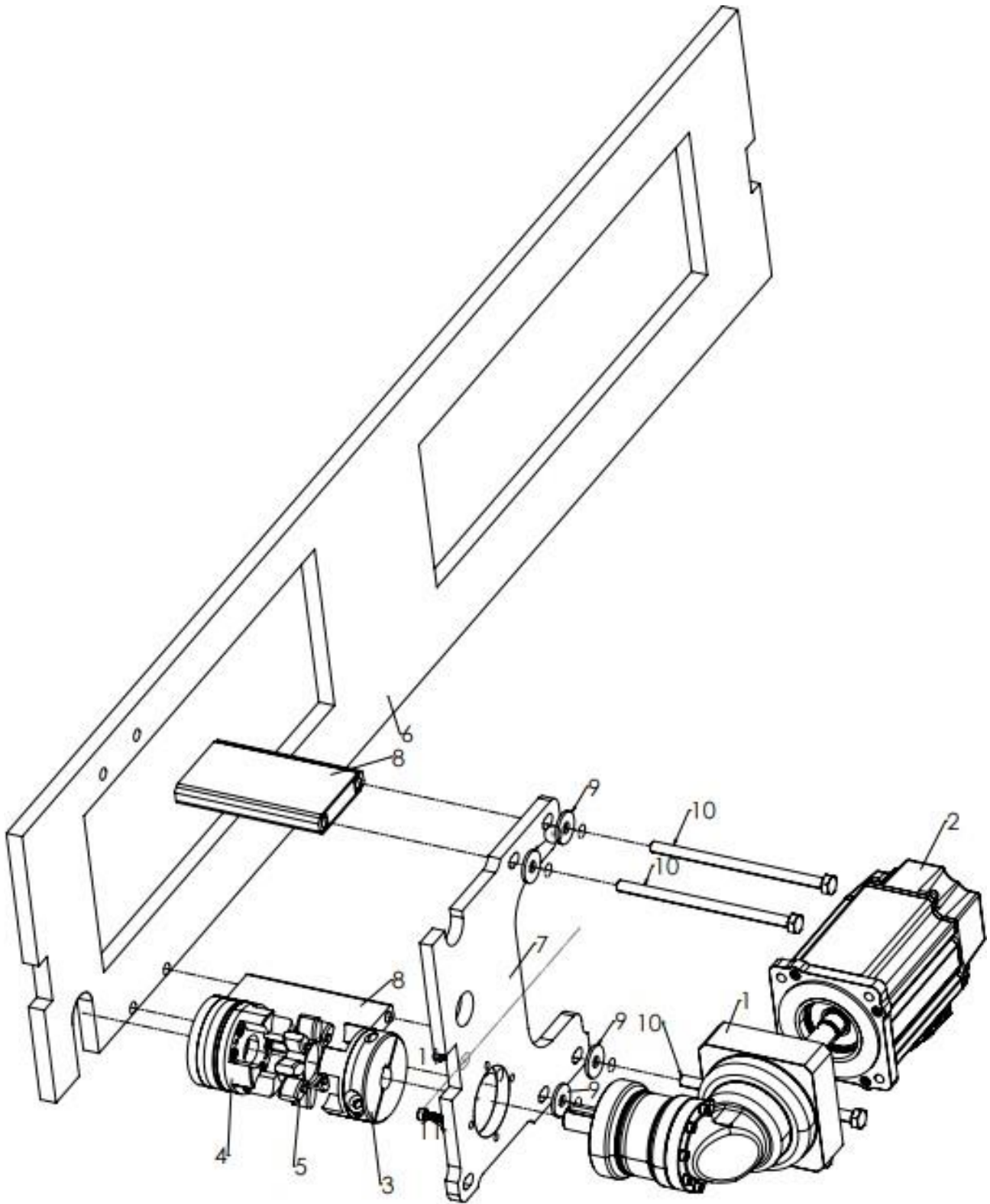



## Servo Drive Assembly Parts List

Ref. No.	Part Description	Q'ty	Part No.	Part No. Factory Manual
1	PE Series Inline Planetary Gearbox	1	55KST-M3-1	
2	Kinetix Vp Low Inertia Servo Motor	1	55KST-M3-2	
3	Rotex Coupling Gearbox Side	1	55KST-M3-3	
4	Rotex Coupling Belt Side	1	55KST-M3-4	
5	Rotex Intermediate Spider	1	55KST-M3-5	
6	Side Plate	2	55KST-M3-6	032-0133
7	Gear Box Mount	2	55KST-M3-7	
8	Spacer Blocks	4	55KST-M3-8	
9	M8 Washer	8	55KST-M3-9	
10	M8x1.25x140mm Hex Bolt	8	55KST-M3-10	
11	M5x0.8x16 Socket Head Cap	8	55KST-M3-11	

# Heater Drive Assembly Diagram

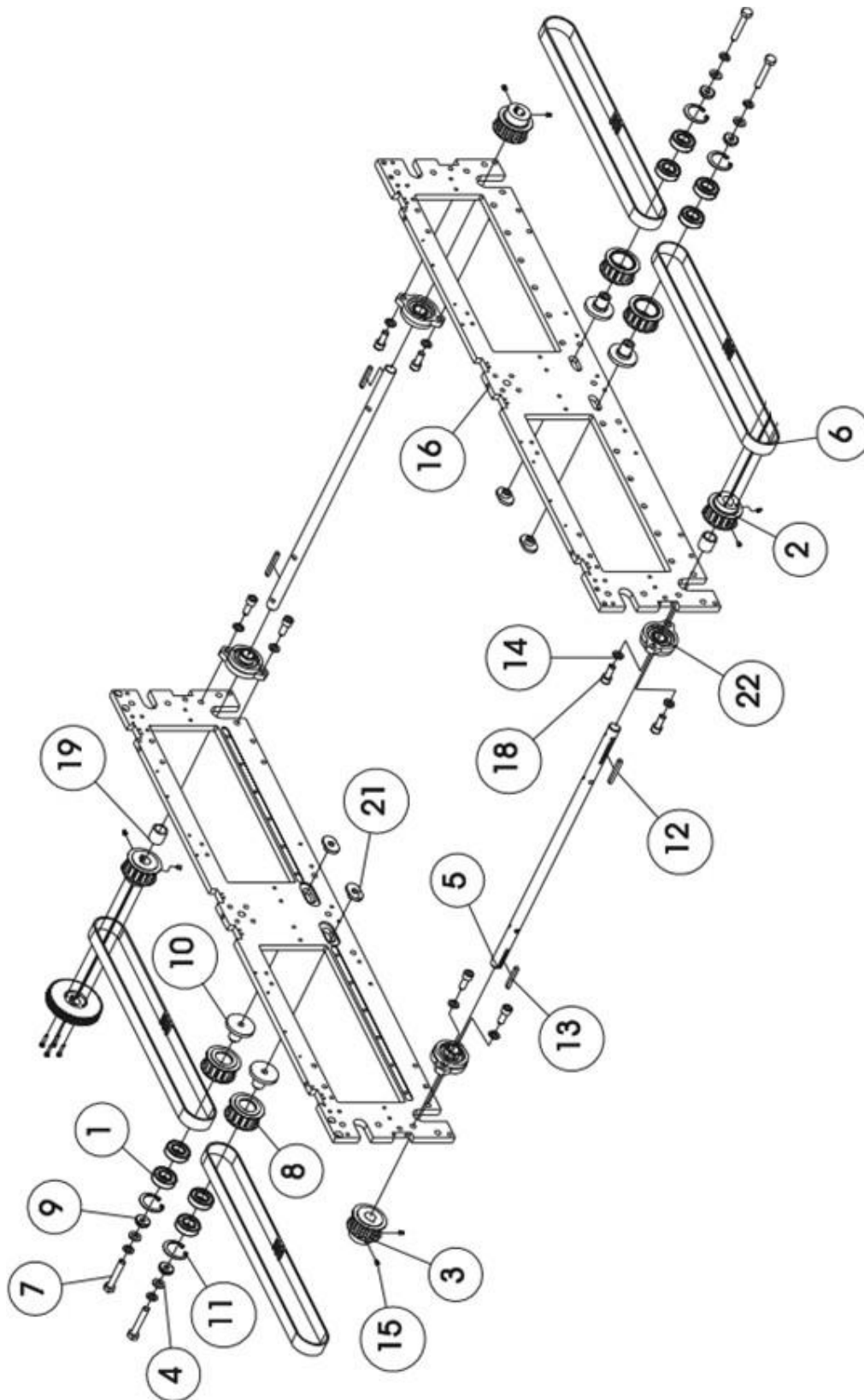

## Heater Drive Assembly Parts List

Ref. No.	Part Description	Q'ty	Part No.	Part No. Factory Manual
1	Ball Bearing	8	55KST-M4-1	BB-6004
2	Drive Pulley	2	55KST-M4-2	032-0017
3	Drive Pulley	2	55KST-M4-3	032-0053
4	Flat Washer	4	55KST-M4-4	FW5610
5	Gearbelt Pulley Drive Shaft	2	55KST-M4-5	032-0048
6	Heater Drive Belt	4	55KST-M4-6	032-0139
7	Hex Head Cap Screw	4	55KST-M4-7	HH1060
8	Idler Pulley	4	55KST-M4-8	032-0016
9	Idler Pulley Clamp	4	55KST-M4-9	032-0025
10	Idler Pulley Mount	4	55KST-M4-10	032-0026
11	Internal Retaining Ring	4	55KST-M4-11	51437-42
12	Key	2	55KST-M4-12	032-0184
13	Key	2	55KST-M4-13	032-0185
14	Lock Washer	12	55KST-M4-14	LW5710
15	Set Screw	8	55KST-M4-15	SS0606
16	Side Plate	2	55KST-M4-16	032-0133
18	Socket Head Cap Screw	8	55KST-M4-18	SH0420
19	Spacer	2	55KST-M4-19	SH1025
21	T-Bolt	4	55KST-M4-21	032-0030
22	Two-Bolt Flange Bearing	4	55KST-M4-22	032-0024

### Conveyor Drive Assembly Diagram (A)

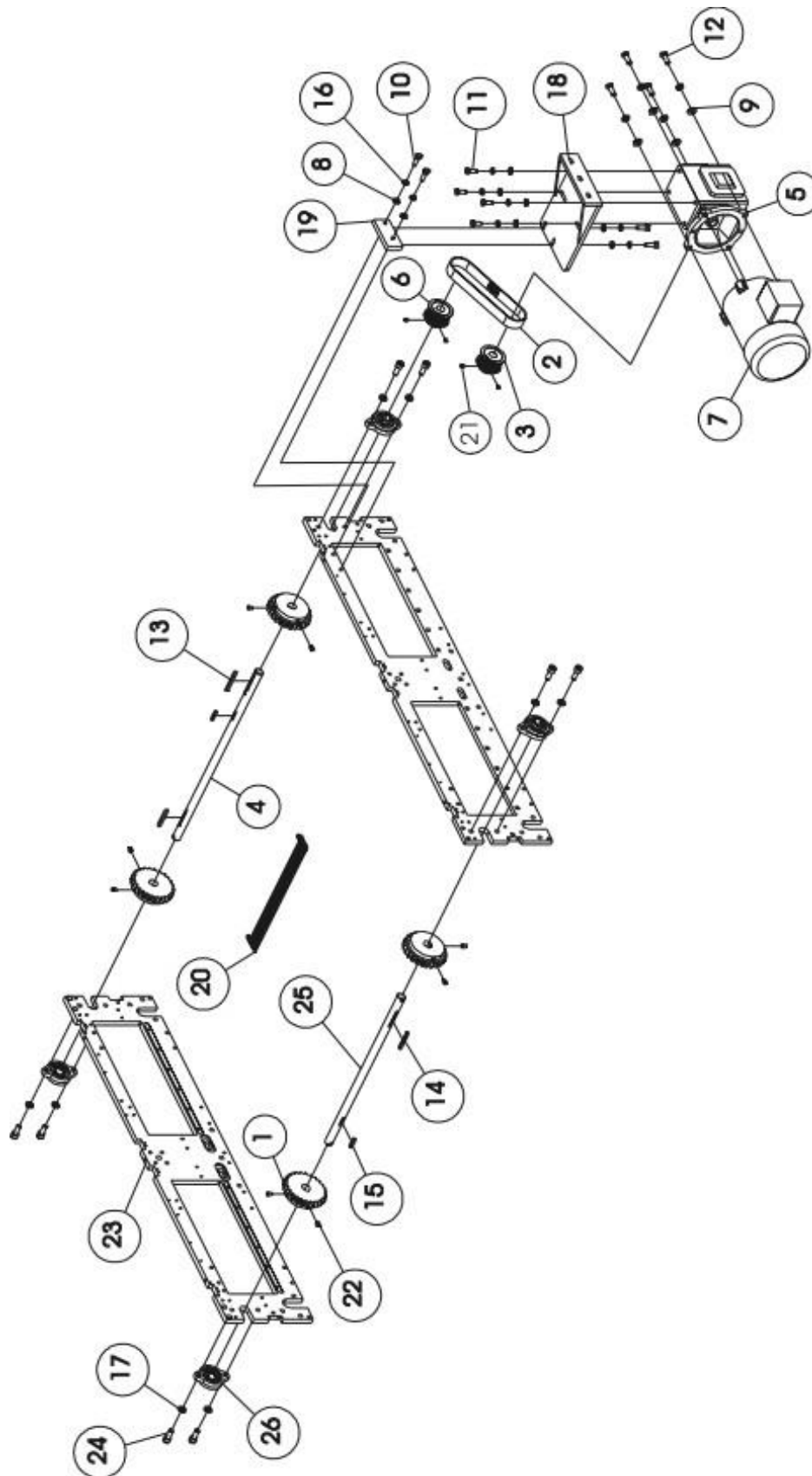

Conveyor Drive Assembly Diagram (B)

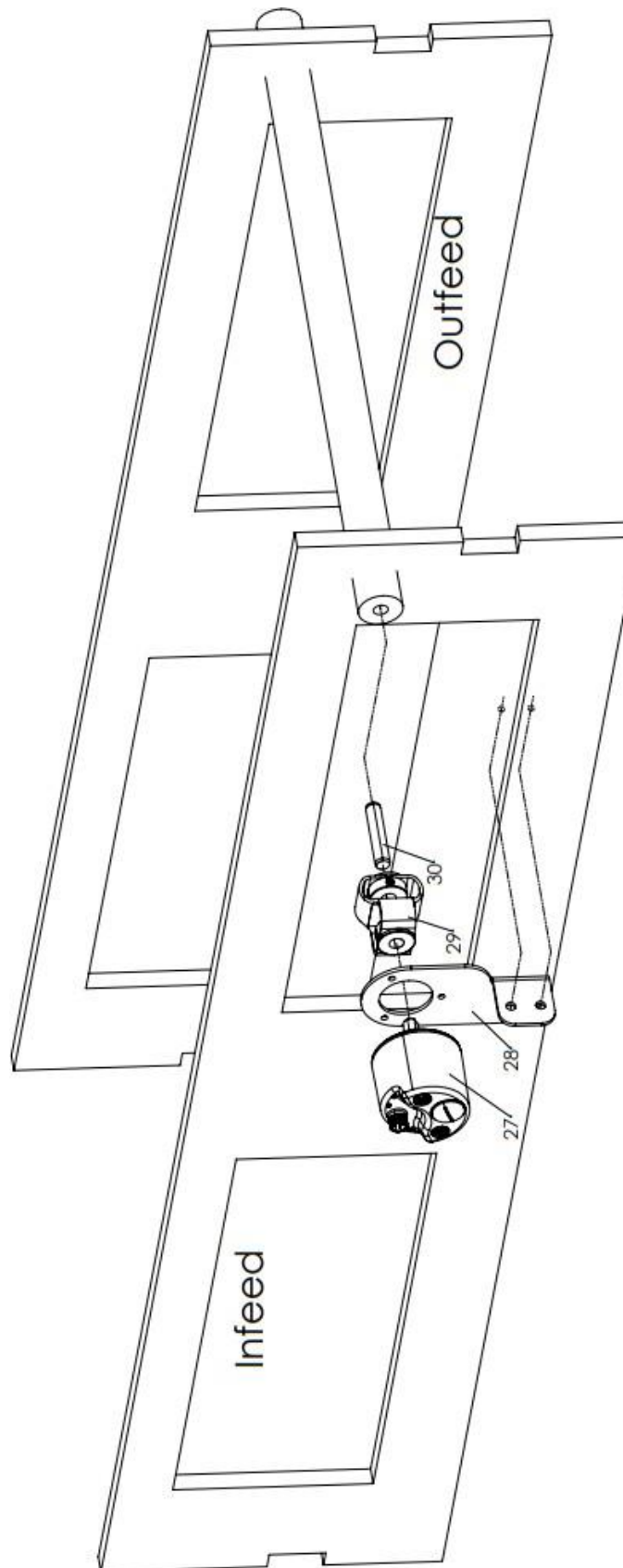

## Conveyor Drive Assembly Parts List

Ref. No.	Part Description	Q'ty	Part No.	Part No. Factory Manual
1	Chain Sprocket	4	55KST-M5-1	032-0018
2	Conveyor Drive Belt	1	55KST-M5-2	032-0180
3	Conveyor Drive Pulley	1	55KST-M5-3	032-0189
4	Conveyor Drive Shaft	1	55KST-M5-4	032-0049
5	Conveyor Gear Reducer	1	55KST-M5-5	032-0143
6	Conveyor Idler Pulley	1	55KST-M5-6	032-0190
7	Conveyor Motor	1	55KST-M5-7	032-0142
8	Flat Washer	8	55KST-M5-8	FW5608
9	Flat Washer	4	55KST-M5-9	FW5610
10	Hex Head Cap Screw	4	55KST-M5-10	HH0825
11	Hex Head Cap Screw	4	55KST-M5-11	SH031100
12	Hex Head Cap Screw	4	55KST-M5-12	HH037100-CMS
13	Key	1	55KST-M5-13	032-0183
14	Key	2	55KST-M5-14	032-0184
15	Key	2	55KST-M5-15	032-0186
16	Lock Washer	8	55KST-M5-16	LW5708
17	Lock Washer	12	55KST-M5-17	LW5710
18	Motor Mount	1	55KST-M5-18	032-0200
19	Motor Mount Bracket	1	55KST-M5-19	032-0118
20	Sani-Grid Wire Belt	1	55KST-M5-20	032-0197
21	Set Screw	4	55KST-M5-21	SS0606
22	Set Screw	8	55KST-M5-22	SS0810
23	Side Plate	2	55KST-M5-23	032-0133
24	Socket Head Cap Screw	8	55KST-M5-24	SH1025
25	Top Idler Shaft	1	55KST-M5-25	032-0047
26	Two-Bolt Flange Bearing	4	55KST-M5-26	032-0193
27	Encoder	1	55KST-M5-27	
28	Encoder Mount	1	55KST-M5-28	
29	Shaft Coupler	1	55KST-M5-29	
30	10mm Dowel Pin	1	55KST-M5-30	

# Conveyor Tensioner Assembly Diagram

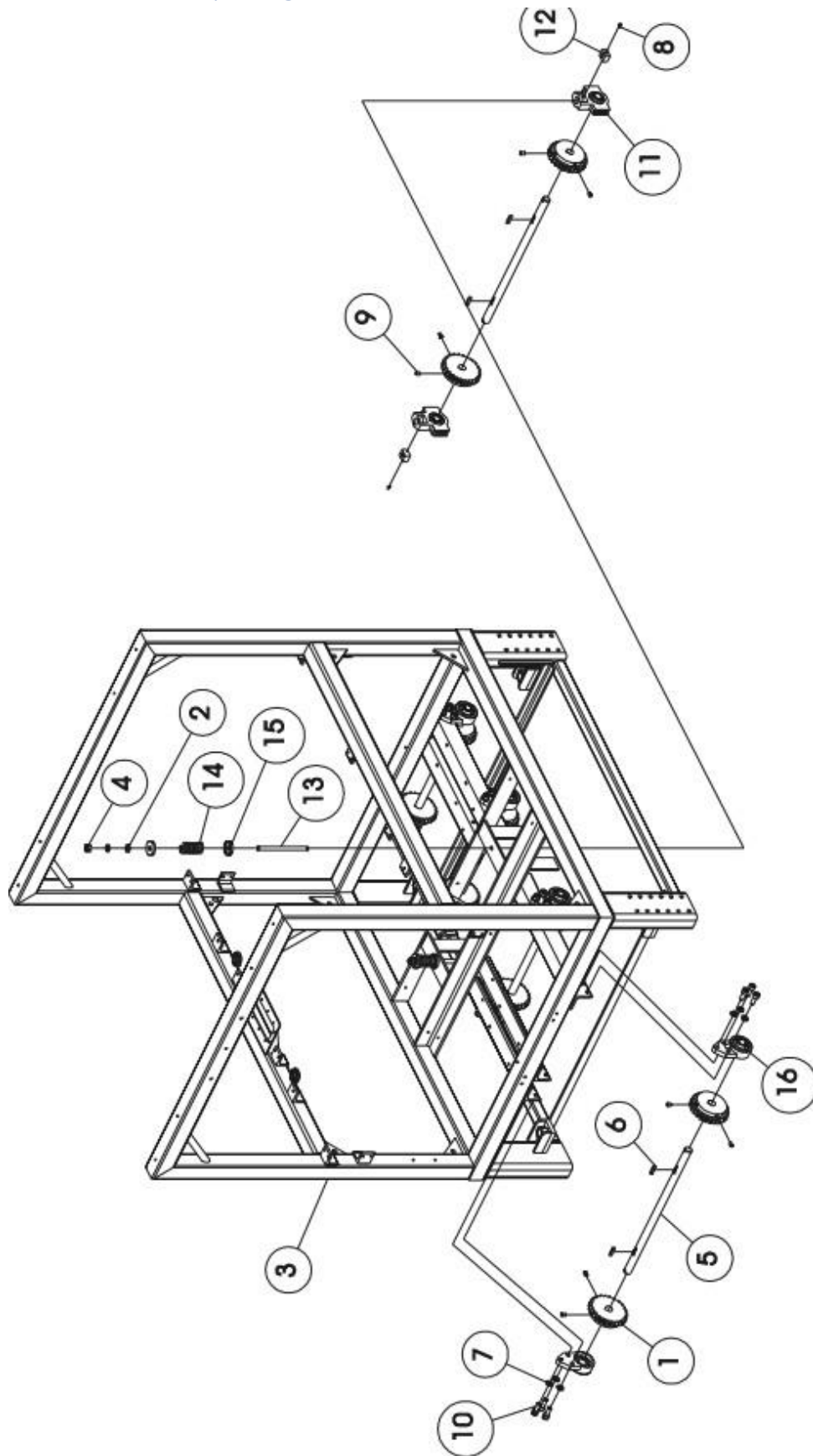

## Conveyor Tensioner Assembly Parts List

Ref. No.	Part Description	Q'ty	Part No.	Part No. Factory Manual
1	Chain Sprocket	10	55KST-M6-1	032-0018
2	Flat Washer	2	55KST-M6-2	FW5610
3	Frame Assembly	1	55KST-M6-3	032-0192
4	Hex Nut	2	55KST-M6-4	HN5510
5	Idler Shaft	5	55KST-M6-5	032-0044
6	Key	10	55KST-M6-6	032-0186
7	Lock Washer	26	55KST-M6-7	LW5710
8	Set Screw	2	55KST-M6-8	SS0606
9	Set Screw	20	55KST-M6-9	SS0810
10	Socket Head Cap Screw	24	55KST-M6-10	SH1025
11	Take-Up Bearing	2	55KST-M6-11	032-0195
12	Tensioner Block	2	55KST-M6-12	032-0050
13	Tensioner Rod	2	55KST-M6-13	032-0135
14	Tensioner Spring	2	55KST-M6-14	032-0136
15	Tensioner Spring Cap	4	55KST-M6-15	032-0134
16	Three-Bolt Flange Bearing	8	55KST-M6-16	032-0194



### Side Plate Mounting Bars Diagram

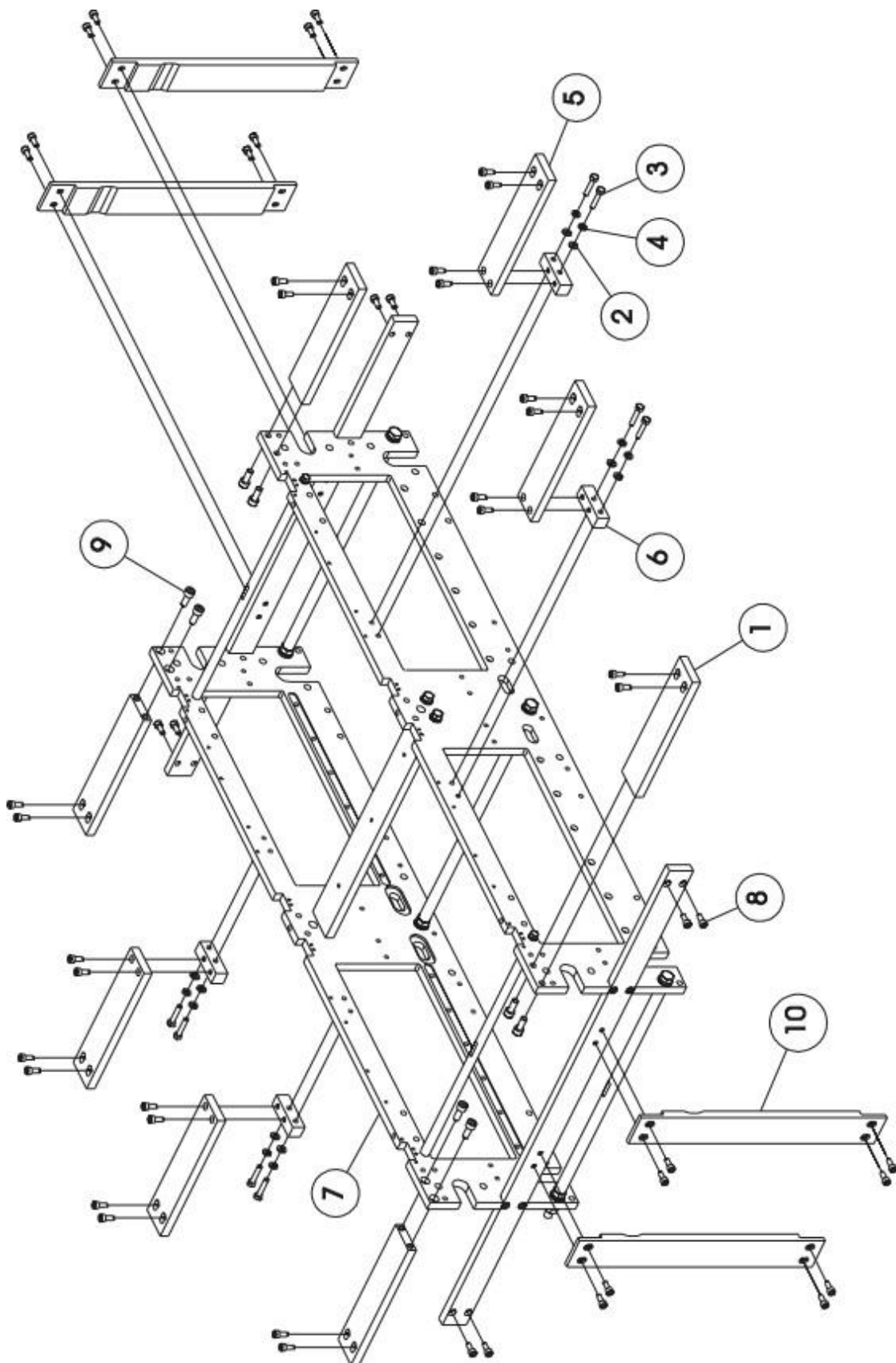

## Side Plate Mounting Bars Parts List

Ref. No.	Part Description	Q'ty	Part No.	Part No. Factory Manual
1	END BRACE	4	55KST-M7-1	032-0115
2	FLAT WASHER	8	55KST-M7-2	FW5606
3	HEX HEAD CAP SCREW	8	55KST-M7-3	HH0630
4	LOCK WASHER	8	55KST-M7-4	LW5706
5	MIDDLE BRACE	4	55KST-M7-5	032-0116
6	MOUNTING BLOCK	4	55KST-M7-6	032-0036
7	SIDE PLATE	1	55KST-M7-7	032-0133
8	SOCKET HEAD CAP SCREW	48	55KST-M7-8	SH0614
9	SOCKET HEAD CAP SCREW	8	55KST-M7-9	SH0820
10	SUPPORT BAR	4	55KST-M7-10	032-0131

### Bottom Heater, Duct & Vent Assembly Diagram

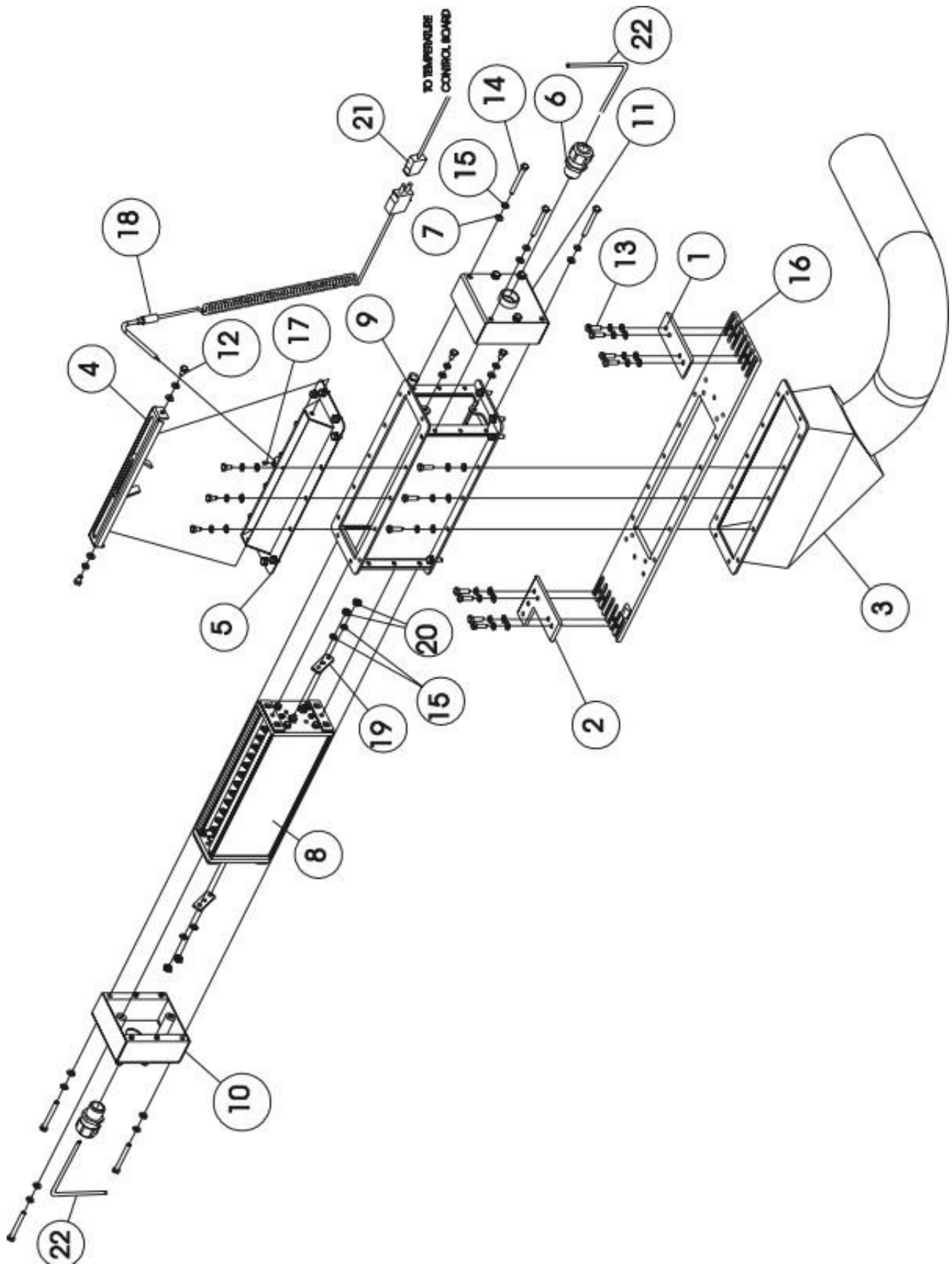

## Bottom Heater, Duct & Vent Assembly Parts List

Ref. No.	Part Description	Q'ty	Part No.	Part No. Factory Manual
1	Belt Clamp	1	55KST-M8-1	032-0101
2	Belt Clamp	1	55KST-M8-2	032-0256
3	Blower Duct	1	55KST-M8-3	032-0107
4	Blower Vent Diffuser	1	55KST-M8-4	032-0274
5	Bottom Blower Vent	1	55KST-M8-5	032-0273
6	Cord Connector	2	55KST-M8-6	ELE-FIT 14
7	Flat Washer	54	55KST-M8-7	FW5605
8	Heater Assembly	1	55KST-M8-8	032-0250
9	Heater Enclosure	1	55KST-M8-9	032-0230
10	Heater Mount & Terminal Cover	1	55KST-M8-10	032-0258
11	Heater Terminal Cover	1	55KST-M8-11	032-0257
12	Hex Head Cap Screw	18	55KST-M8-12	HH0508
13	Hex Head Cap Screw	22	55KST-M8-13	HH0516
14	Hex Head Cap Screw	14	55KST-M8-14	HH0545
15	Lock Washer	54	55KST-M8-15	LW5705
16	Mounting Bar	1	55KST-M8-16	032-0100
17	Set Screw	1	55KST-M8-17	SS0404
18	Thermocouple Probe	1	55KST-M8-18	032-0204
19	Bus Bar	2	55KST-M8-19	032-0254
20	Hex Nut	4	55KST-M8-20	HN5505
21	Thermocouple Socket	1	55KST-M8-21	032-0205
22	Heater Wire	16ft	55KST-M8-22	ELE-WIR-10



## Bottom Heater, Duct &amp; Vent Assembly Parts List

Ref. No.	Part Description	Q'ty	Part No.	Part No. Factory Manual
1	Belt Clamp	1	55KST-M9-1	032-0101
2	Belt Clamp	1	55KST-M9-2	032-0256
3	Blower Duct	1	55KST-M9-3	032-0107
4	Blower Vent Diffuser	1	55KST-M9-4	032-0274
5	Bottom Blower Vent	1	55KST-M9-5	032-0273
6	Cord Connector	2	55KST-M9-6	ELE-FIT 14
7	Flat Washer	54	55KST-M9-7	FW5605
8	Heater Assembly	1	55KST-M9-8	032-0250
9	Heater Enclosure	1	55KST-M9-9	032-0230
10	Heater Mount & Terminal Cover	1	55KST-M9-10	032-0258
11	Heater Terminal Cover	1	55KST-M9-11	032-0257
12	Hex Head Cap Screw	18	55KST-M9-12	HH0508
13	Hex Head Cap Screw	22	55KST-M9-13	HH0516
14	Hex Head Cap Screw	14	55KST-M9-14	HH0545
15	Lock Washer	54	55KST-M9-15	LW5705
16	Mounting Bar	1	55KST-M9-16	032-0100
17	Set Screw	1	55KST-M9-17	SS0404
18	Thermocouple Probe	1	55KST-M9-18	032-0204
19	Bus Bar	2	55KST-M9-19	032-0254
20	Hex Nut	4	55KST-M9-20	HN5505
21	Thermocouple Socket	1	55KST-M9-21	032-0205
22	Heater Wire	16ft	55KST-M9-22	ELE-WIR-10



## Bottom Blower Assembly Parts List

Ref. No.	Part Description	Q'ty	Part No.	Part No. Factory Manual
6	Blower Bellows	2	55KST-M19-6	032-0213
7	Blower Extension	2	55KST-M19-7	032-0173
8	Blower Housing	2	55KST-M19-8	032-0178
9	Blower Motor Cover	2	55KST-M19-9	032-0172
10	Blower Wheel	2	55KST-M19-10	032-0179
11	Bottom Blower Motor	2	55KST-M19-11	032-0176
15	Flat Washer	16	55KST-M19-15	FW5605
16	Flat Washer	34	55KST-M19-16	FW5606
17	Flat Washer	8	55KST-M19-17	FW5608
18	Frame Assembly	1	55KST-M19-18	032-0192
21	Hex Head Cap Screw	8	55KST-M19-21	HH0516
22	Hex Head Cap Screw	4	55KST-M19-22	HH0545
24	Hex Head Cap Screw	10	55KST-M19-24	HH0630
25	Hex Head Cap Screw	8	55KST-M19-25	HH0816
27	Hex Nut	10	55KST-M19-27	HN5506
30	Lock Washer	16	55KST-M19-30	LW5705
31	Lock Washer	20	55KST-M19-31	LW5706
32	Lock Washer	8	55KST-M19-32	LW5707
41	Worm-Drive Hose Clamp	2	55KST-M19-41	032-0220



# Hood & Guard Assembly Diagram

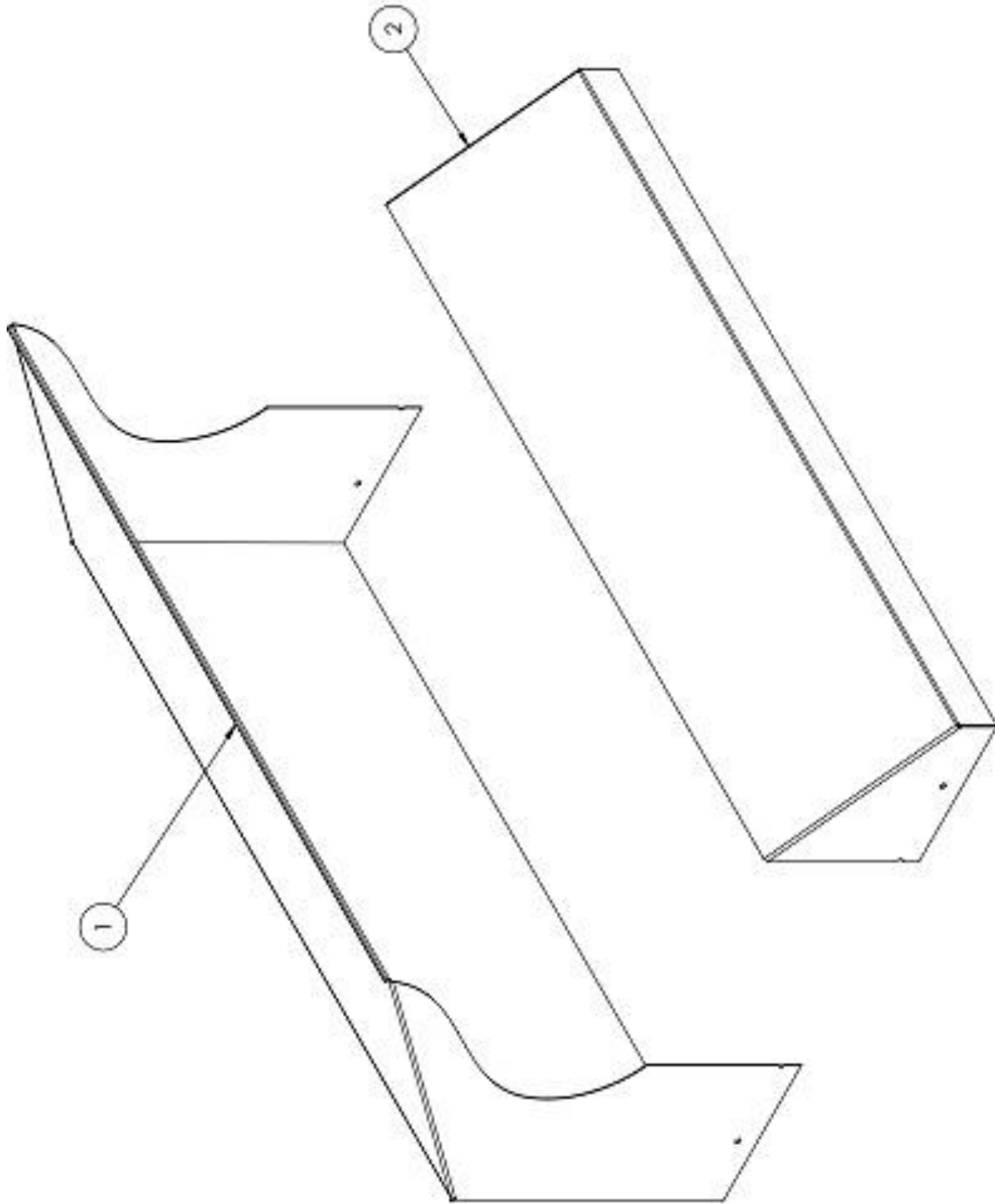

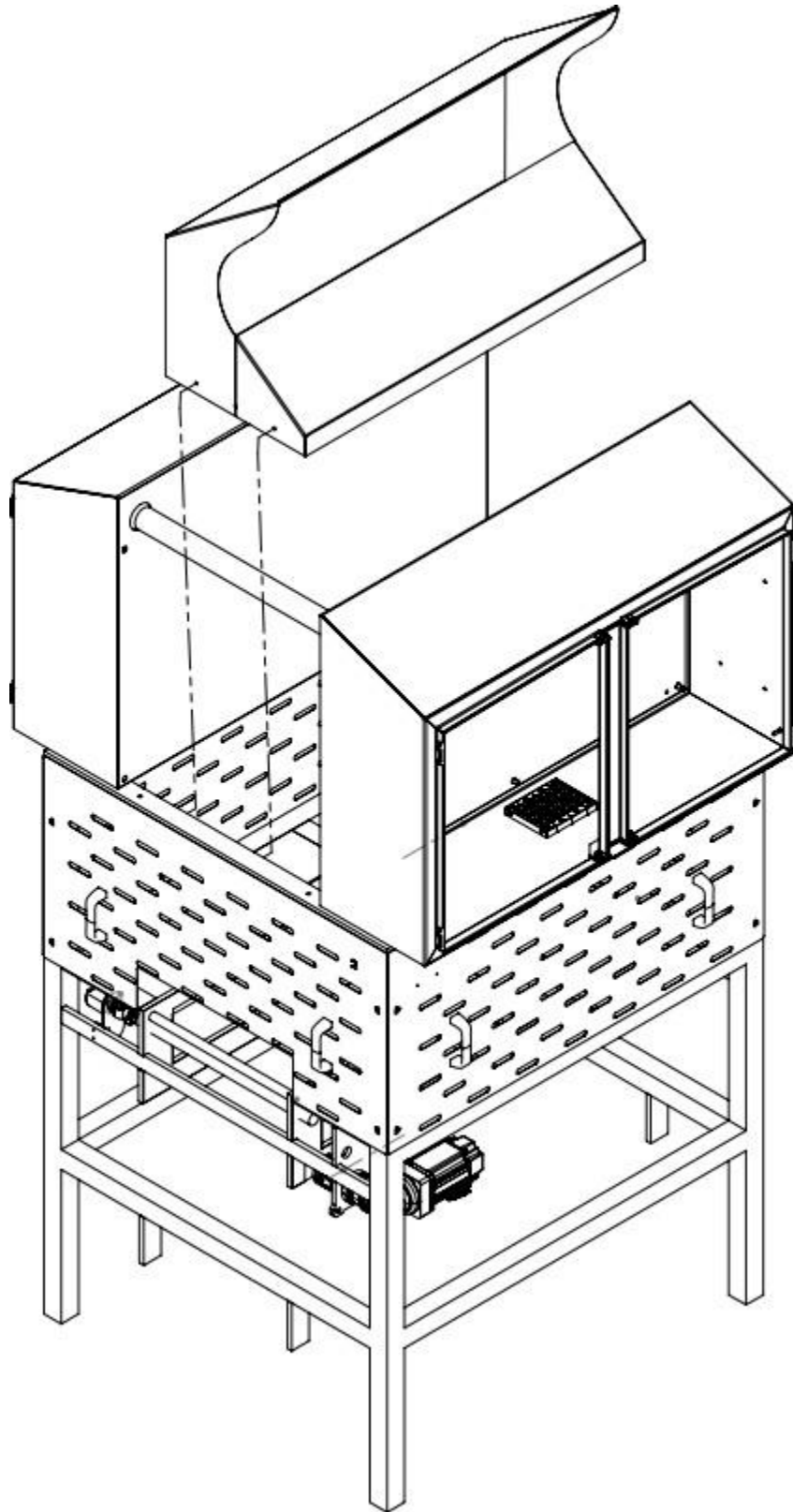

## Hood & Guard Assembly Diagram

Ref. No.	Part Description	Q'ty	Part No.	Part No. Factory Manual
1	Hood Non-Op Side	1	55KST-M21-1	
2	Hood Op Side	1	55KST-M21-2	

# Control Panel Assembly Diagram

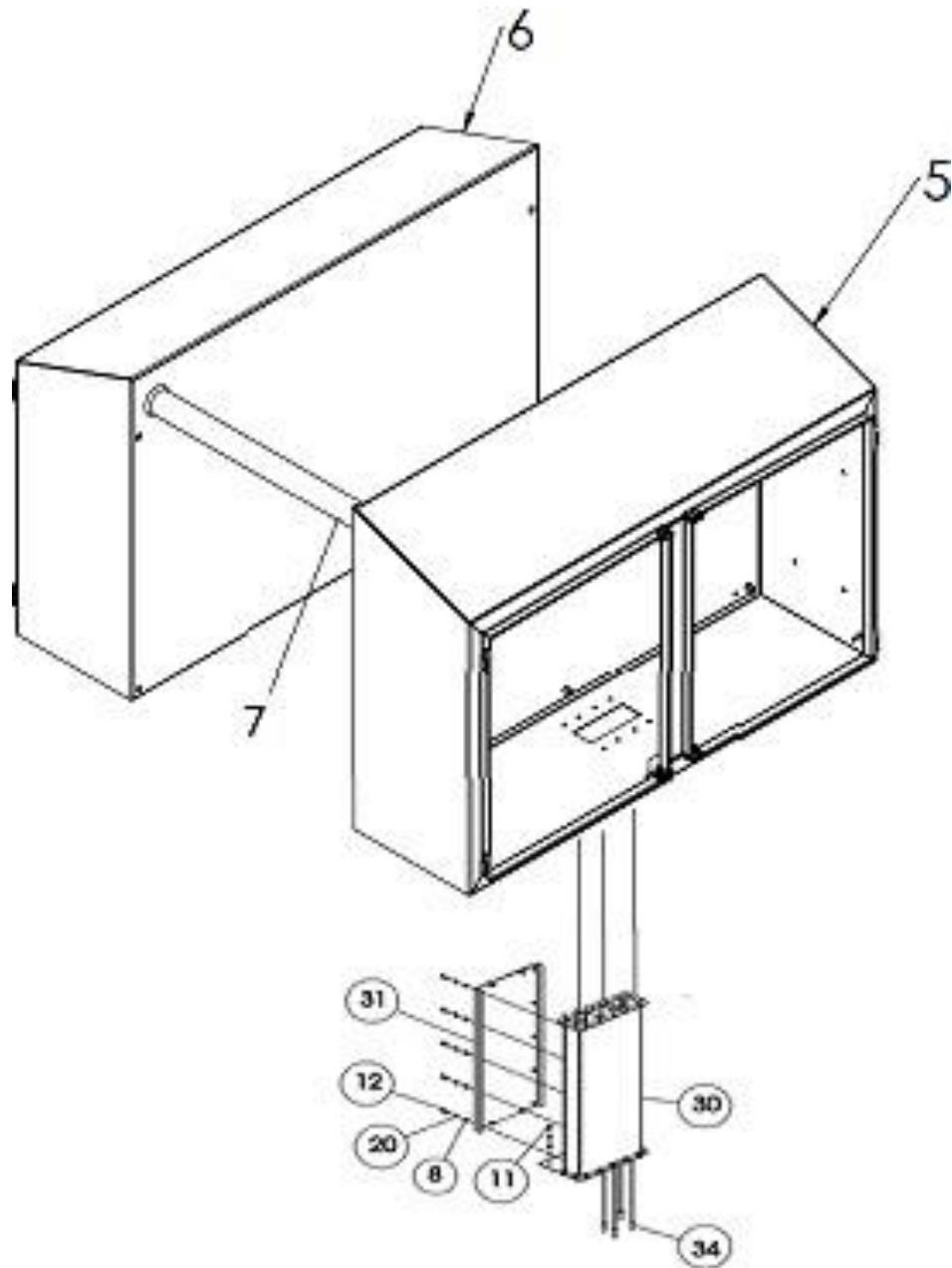

## Control Panel Assembly Parts List

Ref. No.	Part Description	Q'ty	Part No.	Part No. Factory Manual
5	Operator Side Small Control Panel	1	55KST-M11-5	
6	Non-Op Side Large Control Panel	1	55KST-M11-6	
7	Cooling Tube / Cable Routing Tube	2	55KST-M11-7	
8	Flat Washer	30	55KST-M11-8	
11	Hex Head Cap Screw	12	55KST-M11-9	
12	Hex Head Cap Screw	18	55KST-M11-10	
30	Lock Washer	30	55KST-M11-11	
31	Wireway	1	55KST-M11-12	
34	Wireway Cover	1	55KST-M11-13	

# Transfer Roller Assembly Diagram

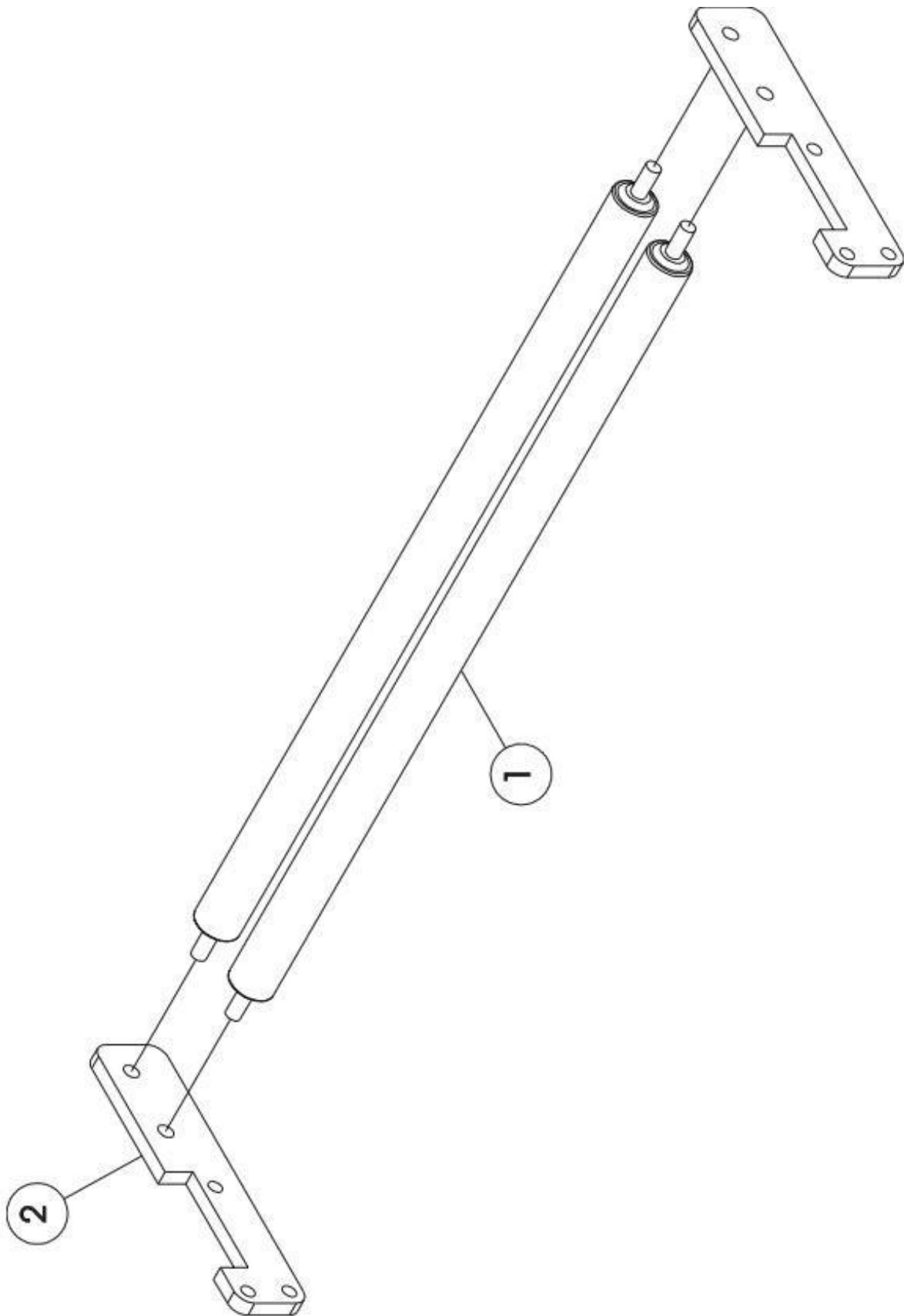

## Transfer Roller Assembly Parts List

Ref. No.	Part Description	Q'ty	Part No.	Part No. Manual
1	Transfer Roller	2	55KST-M12-1	032-0304
2	Transfer Roller Bracket	2	55KST-M12-2	032-0303

## Bottom Trays & Covers Diagram

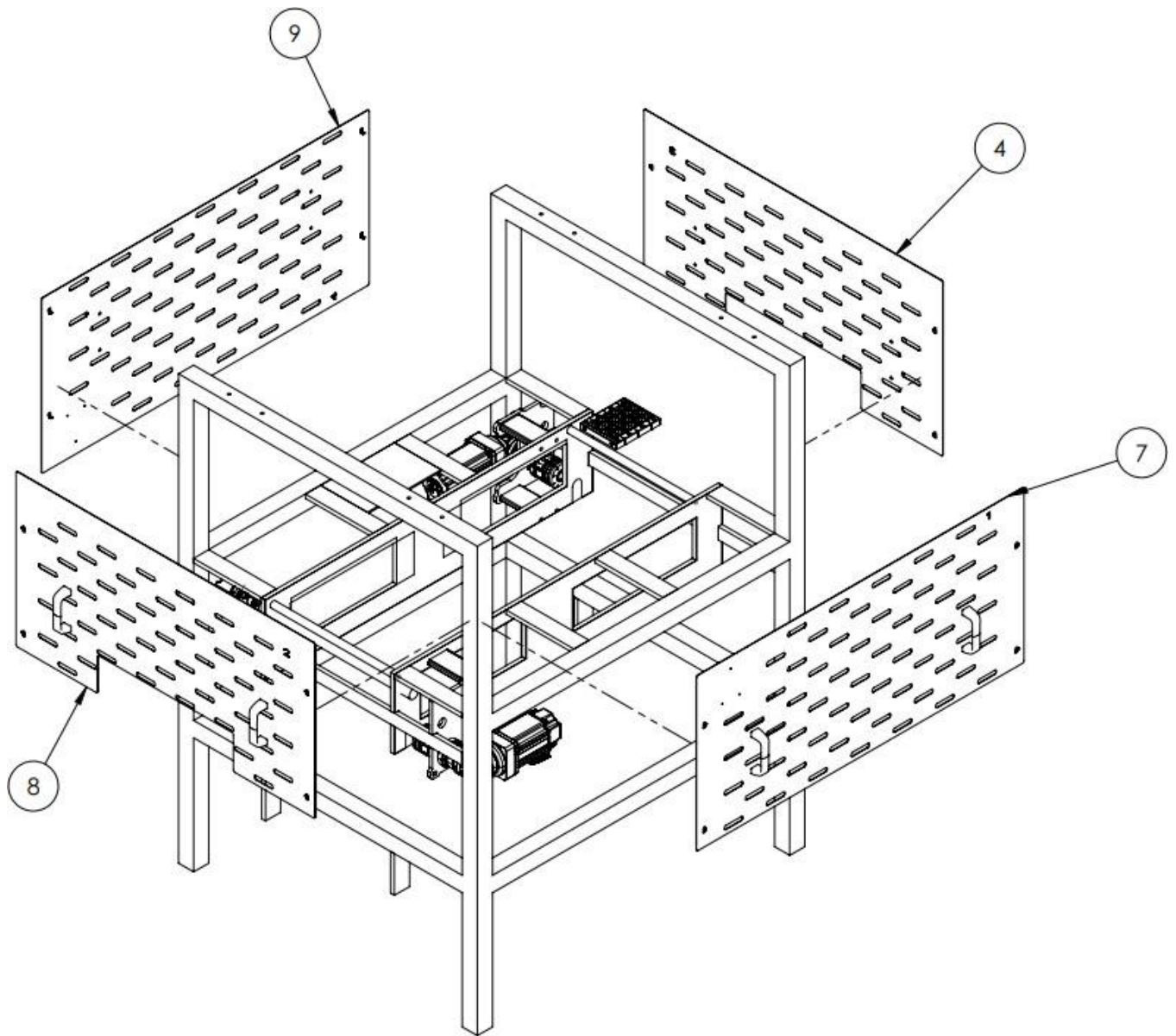



## Bottom Trays &amp; Covers Parts List

<b>Ref. No.</b>	<b>Part Description</b>	<b>Q'ty</b>	<b>Part No.</b>	<b>Part No. Factory Manual</b>
4	Infeed Cover	1	55KST-M13-4	
7	Operator Side Cover	1	55KST-M13-7	
8	Outfeed Cover	1	55KST-M13-8	
9	Non-Op Sie Cover	2	55KST-M13-9	

# Package Guide & Sensors Diagram

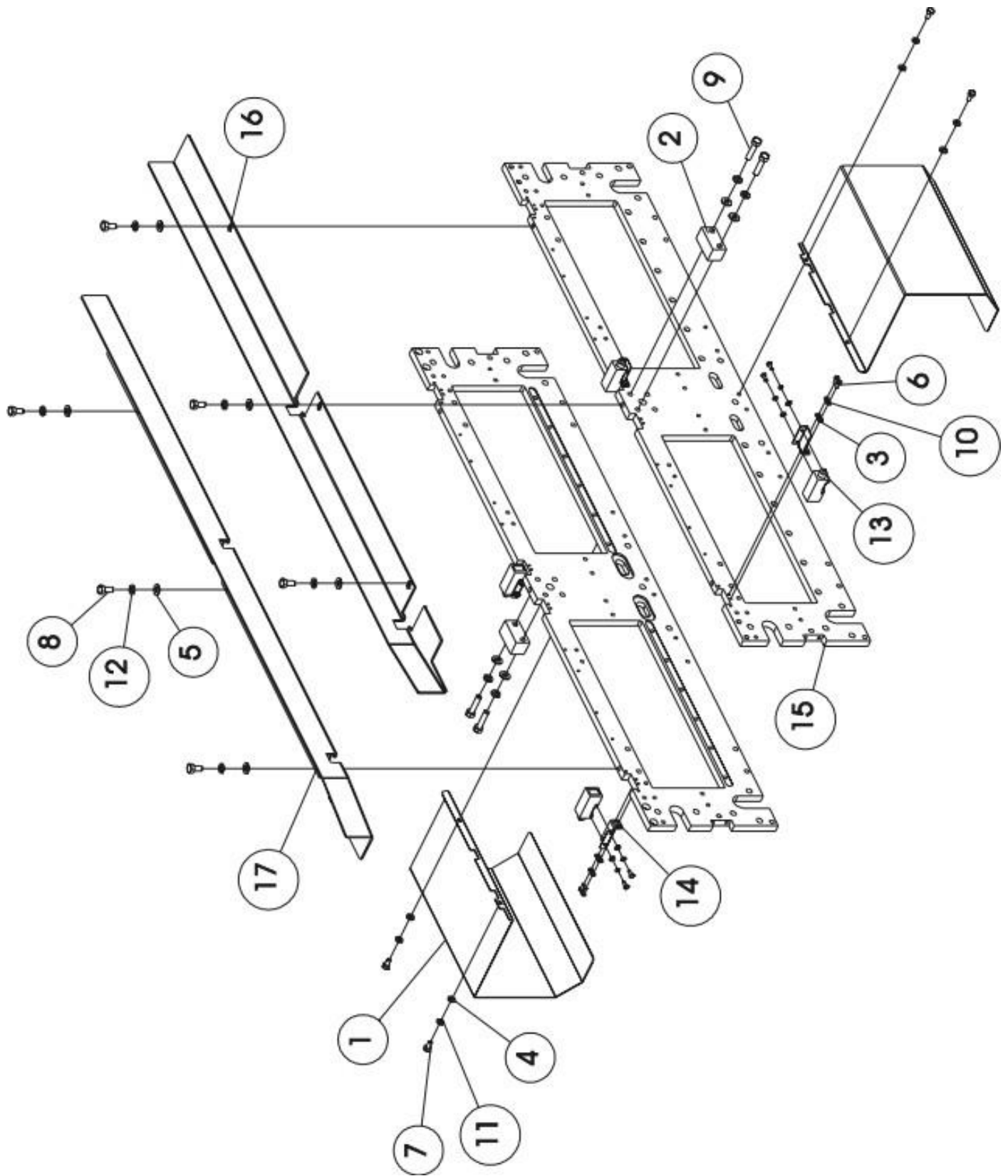

## Package Guide & Sensors Parts List

Ref. No.	Part Description	Q'ty	Part No.	Part No. Factory Manual
1	Belt Guard	2	55KST-M14-1	032-0162
2	Block	2	55KST-M14-2	032-0141
3	Flat Washer	16	55KST-M14-3	FW5604
4	Flat Washer	4	55KST-M14-4	FW5606
5	Flat Washer	10	55KST-M14-5	FW5608
6	Hex Head Cap Screw	16	55KST-M14-6	HH0410
7	Hex Head Cap Screw	4	55KST-M14-7	HH0612
8	Hex Head Cap Screw	6	55KST-M14-8	HH0816
9	Hex Head Cap Screw	4	55KST-M14-9	HH0835
10	Lock Washer	16	55KST-M14-10	LW5704
11	Lock Washer	4	55KST-M14-11	LW5706
12	Lock Washer	10	55KST-M14-12	LW5708
13	Photoelectric Switch	4	55KST-M14-13	E-3591
14	Photoelectric Switch Bracket	4	55KST-M14-14	032-0239
15	Side Plate	2	55KST-M14-15	032-0133
16	Packaging Guide	1	55KST-M14-16	032-0153
17	Packaging Guide	1	55KST-M14-17	032-0154

# Shelf Covers & Mounting Feet Diagram

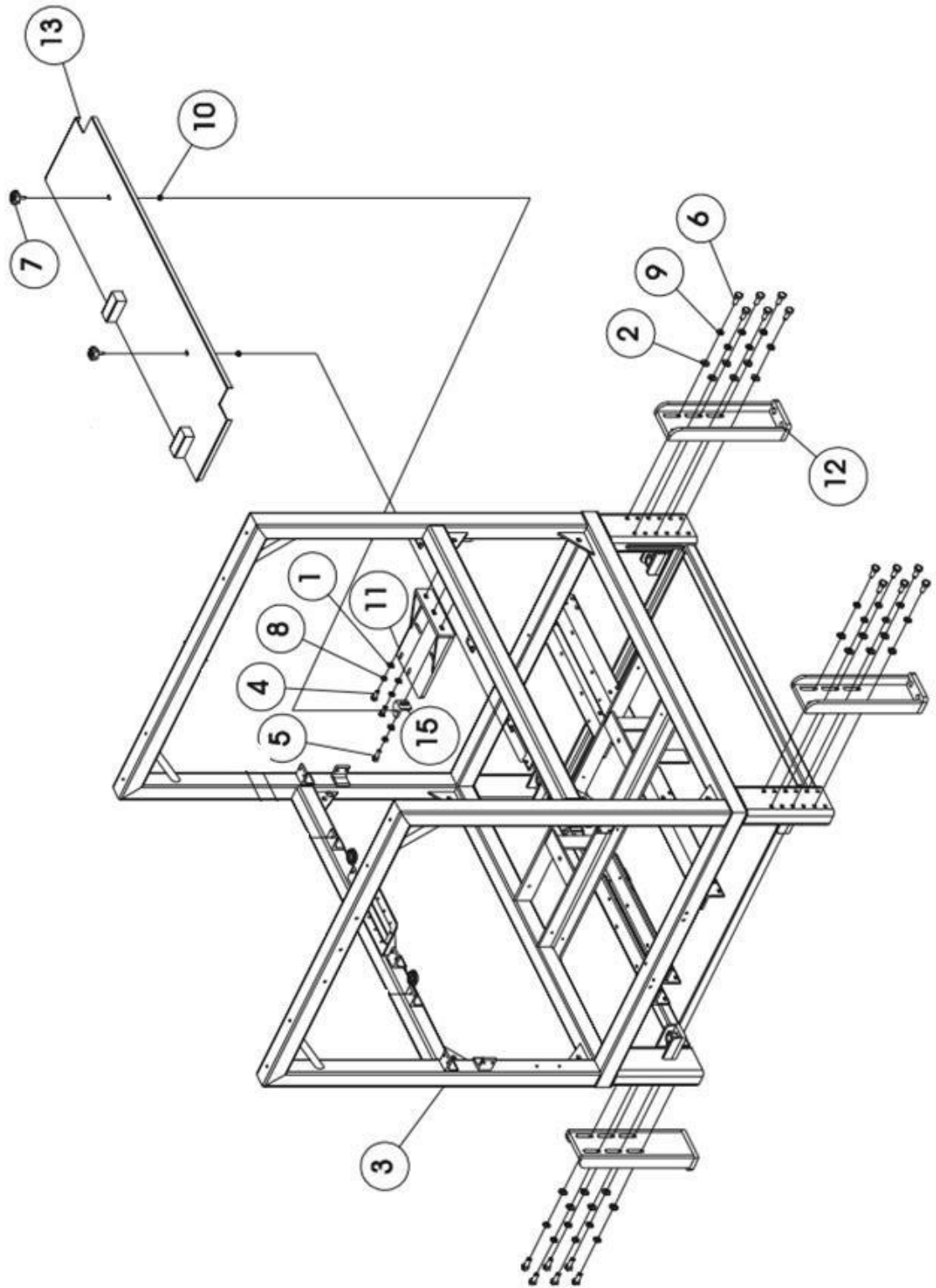

## Shelf Covers &amp; Mounting Feet Parts List

Ref. No.	Part Description	Q'ty	Part No.	Part No. Factory Manual
1	Flat Washer	3	55KST-M15-1	FW5608
2	Flat Washer	24	55KST-M15-2	FW5610
3	Frame Assembly	1	55KST-M15-3	032-0192
4	Hex Head Cap Screw	2	55KST-M15-4	HH0820
5	Hex Head Cap Screw	1	55KST-M15-5	HH0825
6	Hex Head Cap Screw	24	55KST-M15-6	HH1025
7	Knob Assembly	4	55KST-M15-7	41-2871-3
8	Lock Washer	3	55KST-M15-8	LW5708
9	Lock Washer	24	55KST-M15-9	LW5710
10	Locking Nut	4	55KST-M15-10	032-0238
11	Motor Mount	1	55KST-M15-11	032-0200
12	Mounting Foot	4	55KST-M15-12	032-0096
13	Shelf Cover	1	55KST-M15-13	032-0209
15	Shelf Cover Bracket	1	55KST-M15-15	032-0222

# End Flap Blow Down Assembly Diagram

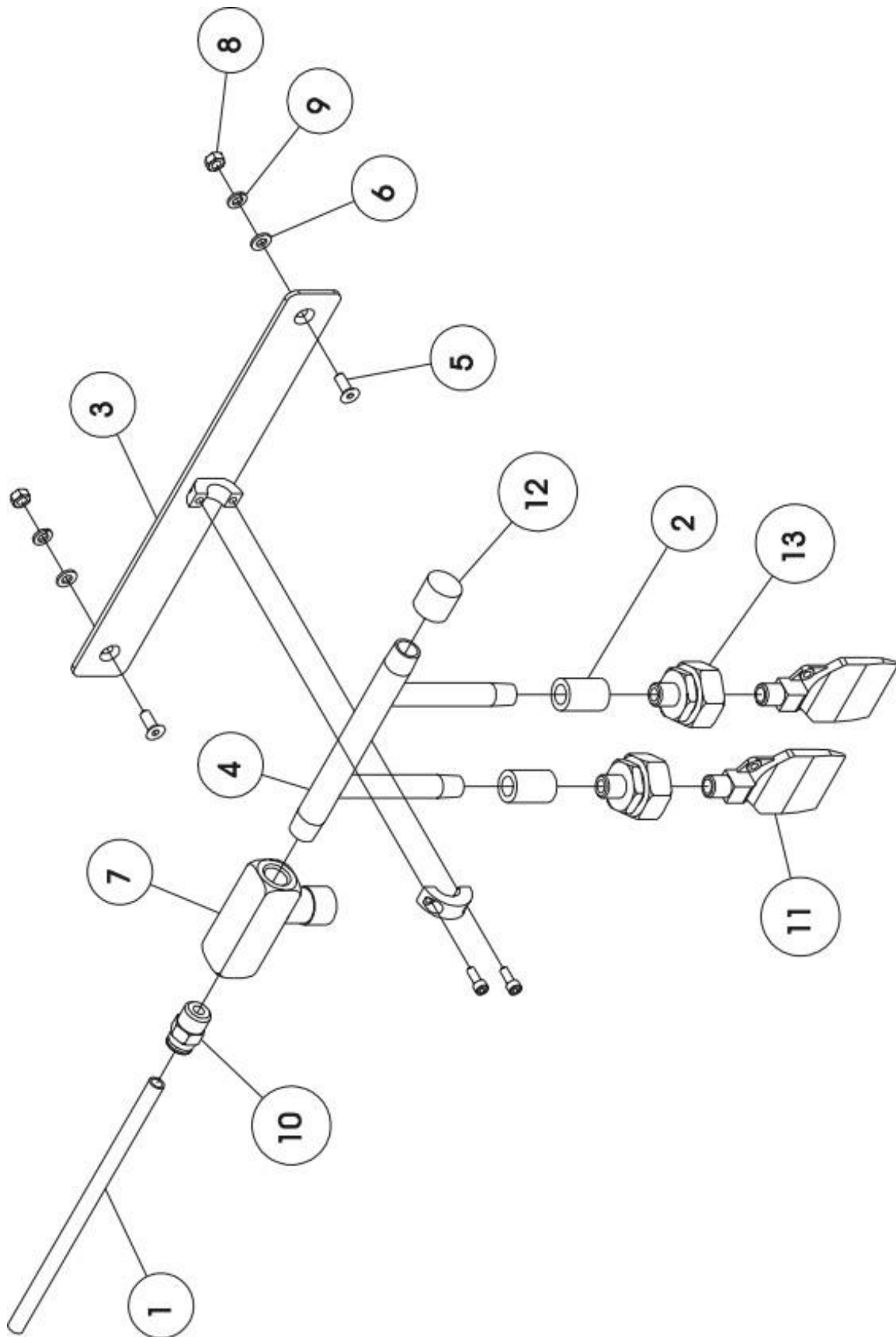

## End Flap Blow Down Assembly Parts List

Ref. No.	Part Description	Q'ty	Part No.	Part No. Factory Manual
1	Air Tubing	1	55KST-M20-1	
2	Coupling	2	55KST-M20-2	
3	End Flap Blow Down Assy. Mount	1	55KST-M20-3	
4	End Flap Blow Down Manifold	1	55KST-M20-4	
5	Flat Head Socket Cap Screw	2	55KST-M20-5	
6	Flat Washer	2	55KST-M20-6	
7	Flow Control	1	55KST-M20-7	
8	Hex Nut	2	55KST-M20-8	
9	Lock Washer	2	55KST-M20-9	
10	Male Connector	1	55KST-M20-10	
11	Nozzle	2	55KST-M20-11	
12	Pipe Cap	1	55KST-M20-12	
13	Swivel Joint	2	55KST-M20-13	





## Heater Position Sensors Parts List

Ref. No.	Part Description	Q'ty	Part No.	Part No. Factory Manual
2	Flat Washer	8	55KST-M16-2	FW5606
4	Lock Washer	8	55KST-M16-4	LW5706
6	Proximity Switch	4	55KST-M16-6	ELE-PRX-04
8	Sensor Bracket	4	55KST-M16-8	032-0150
9	Sensor Cable	4	55KST-M16-9	ELE-CAB-02
11	Side Plate	1	55KST-M16-11	032-0133
13	Socket Head Cap Screw	8	55KST-M16-13	SH0614
14	Sensor Bracket	2	55KST-M16-14	
15	Photoelectric Sensor	2	55KST-M16-15	

# Flexible Wireway Diagram (A)

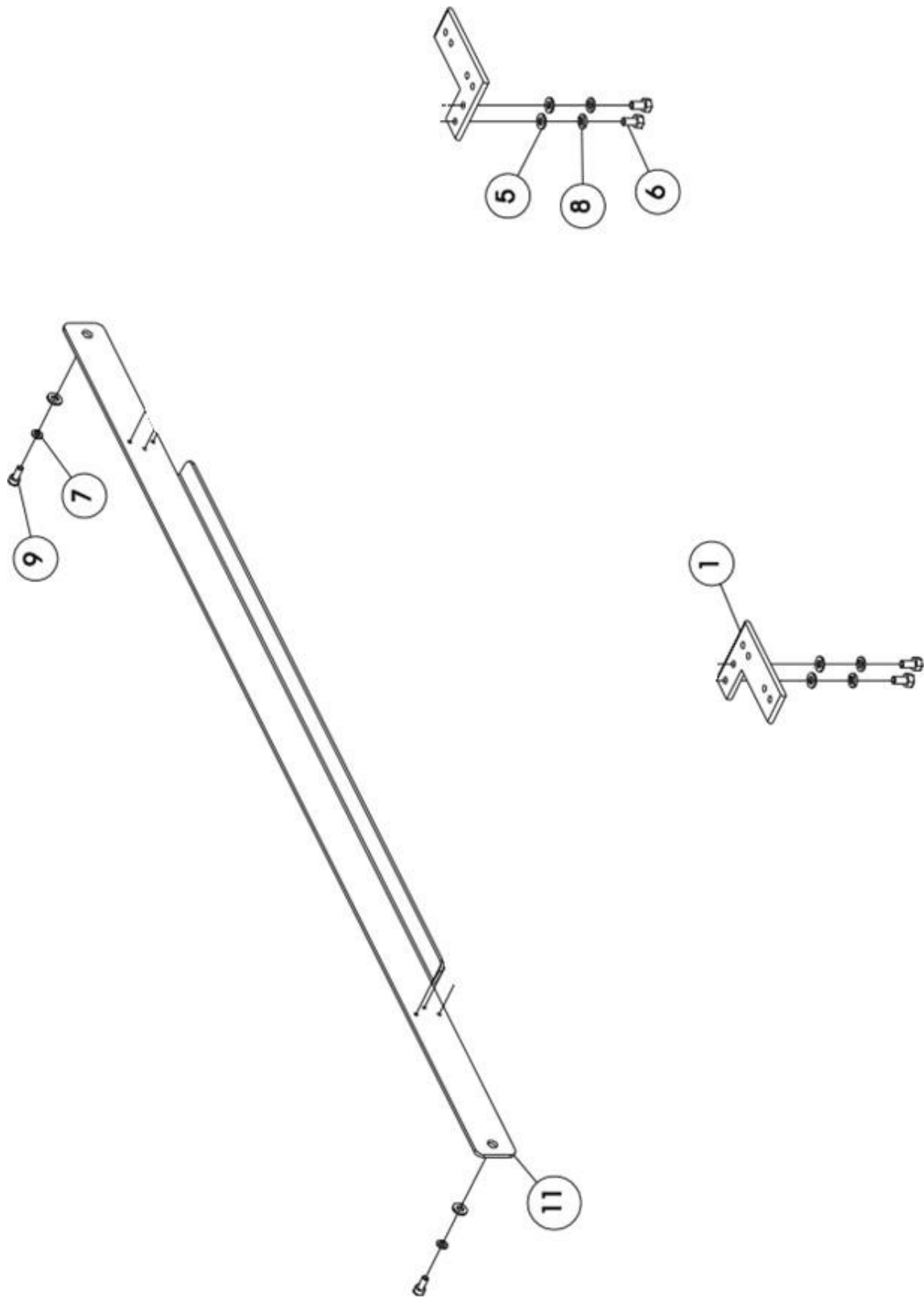

Flexible Wireway Diagram (B)

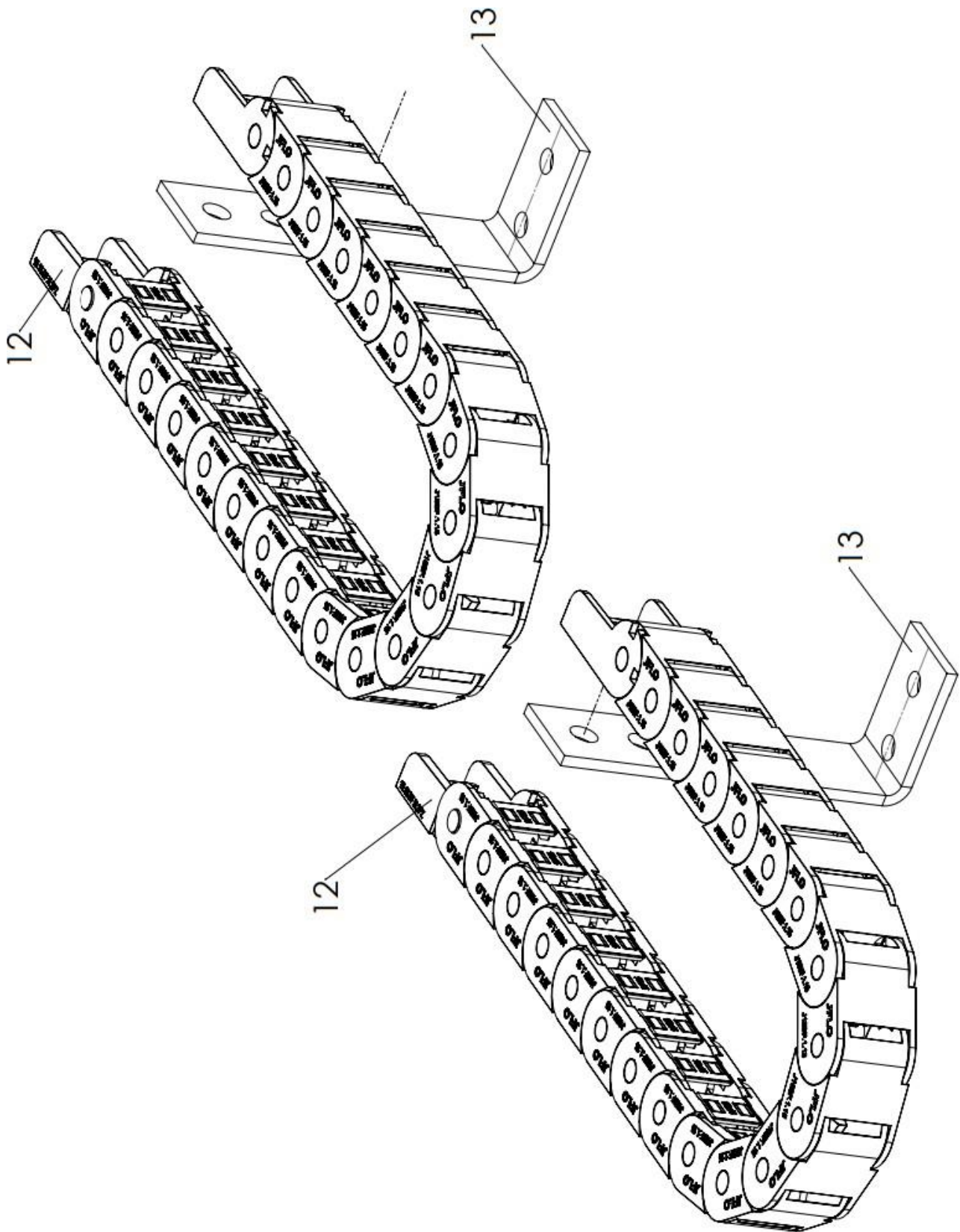

## Flexible Wireway Parts List

Ref. No.	Part Description	Q'ty	Part No.	Part No. Factory Manual
1	Belt Clamp	2	55KST-M17-1	032-0256
5	Flat Washer	6	55KST-M17-5	FW5606
6	Hex Head Cap Screw	4	55KST-M17-6	HH0612
7	Lock Washer	2	55KST-M17-7	LW5705
8	Lock Washer	4	55KST-M17-8	LW5706
9	Socket Head Cap Screw	2	55KST-M17-9	SH0512
11	Wireway Mount	1	55KST-M17-11	032-0263
12	Lapp Cable Track	2	55KST-M17-12	
13	Cable Track Mt	2	55KST-M17-13	

# Height Adjustment & Casters Diagram

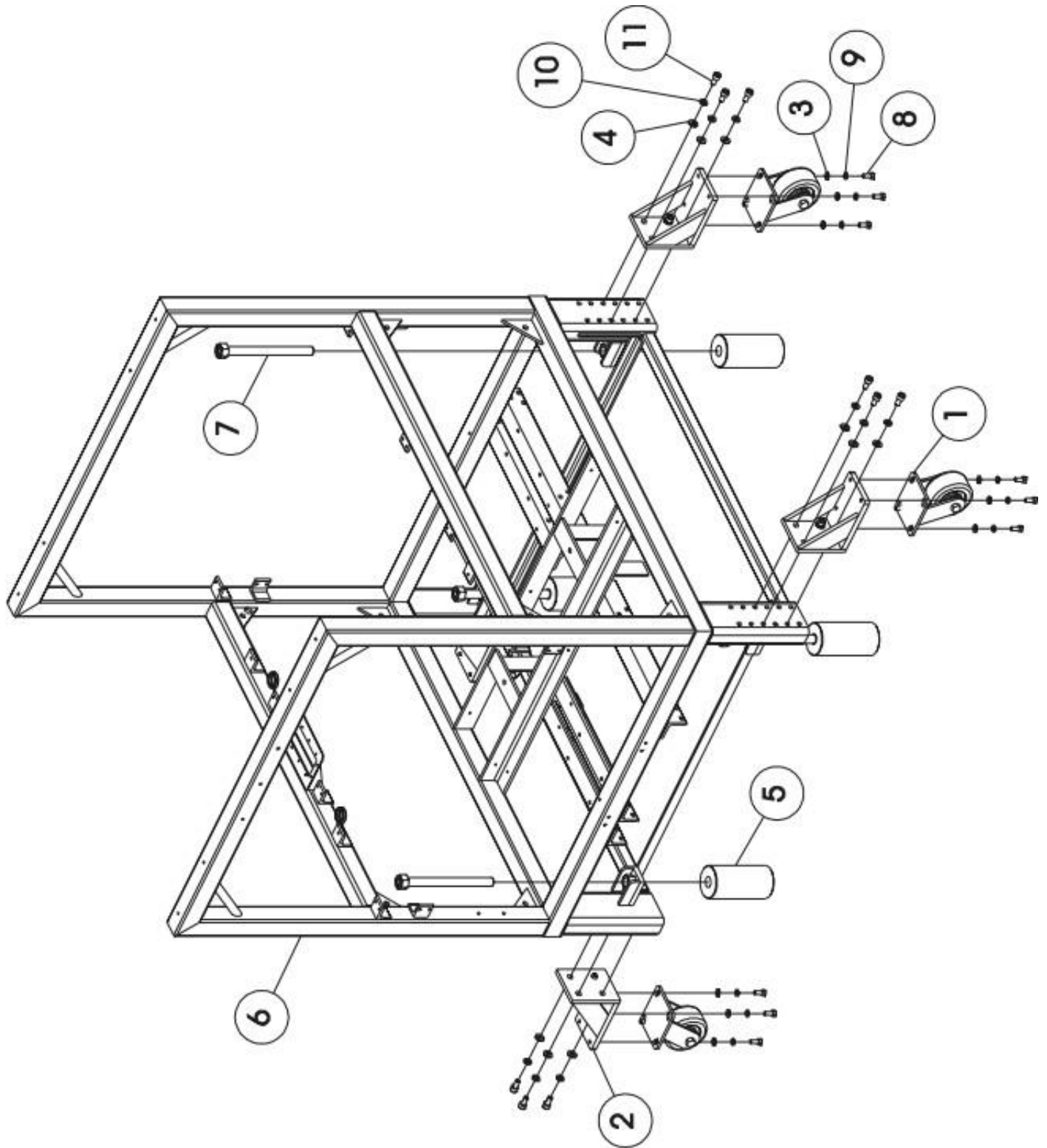

## Height Adjustment & Casters Parts List

Ref. No.	Part Description	Q'ty	Part No.	Part No. Factory Manual
1	Caster	4	55KST-M18-1	ID500-B1-A
2	Caster Mount	4	55KST-M18-2	032-0119
3	Flat Washer	16	55KST-M18-3	FW5608
4	Flat Washer	16	55KST-M18-4	FW5610
5	Foot Pad	4	55KST-M18-5	032-0215
6	Frame Assembly	1	55KST-M18-6	032-0192
7	Height Adjustment Screw	4	55KST-M18-7	032-0240
8	Hex Head Cap Screw	16	55KST-M18-8	HH0820
9	Lock Washer	16	55KST-M18-9	LW5708
10	Lock Washer	16	55KST-M18-10	LW5710
11	Socket Head Cap Screw	16	55KST-M18-11	SH1020

# Low Voltage Diagram (A)

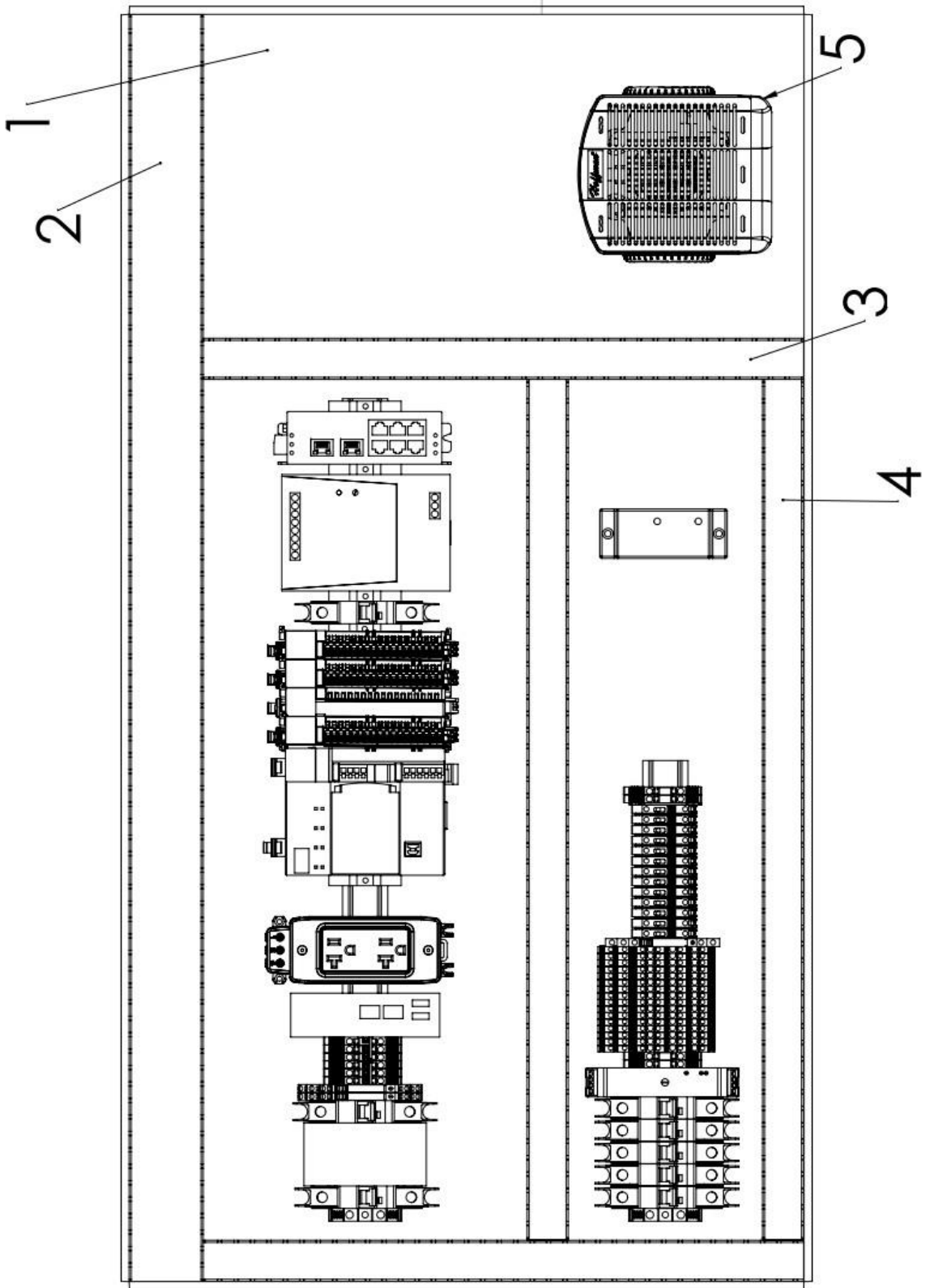

Low Voltage Panel Diagram (B)

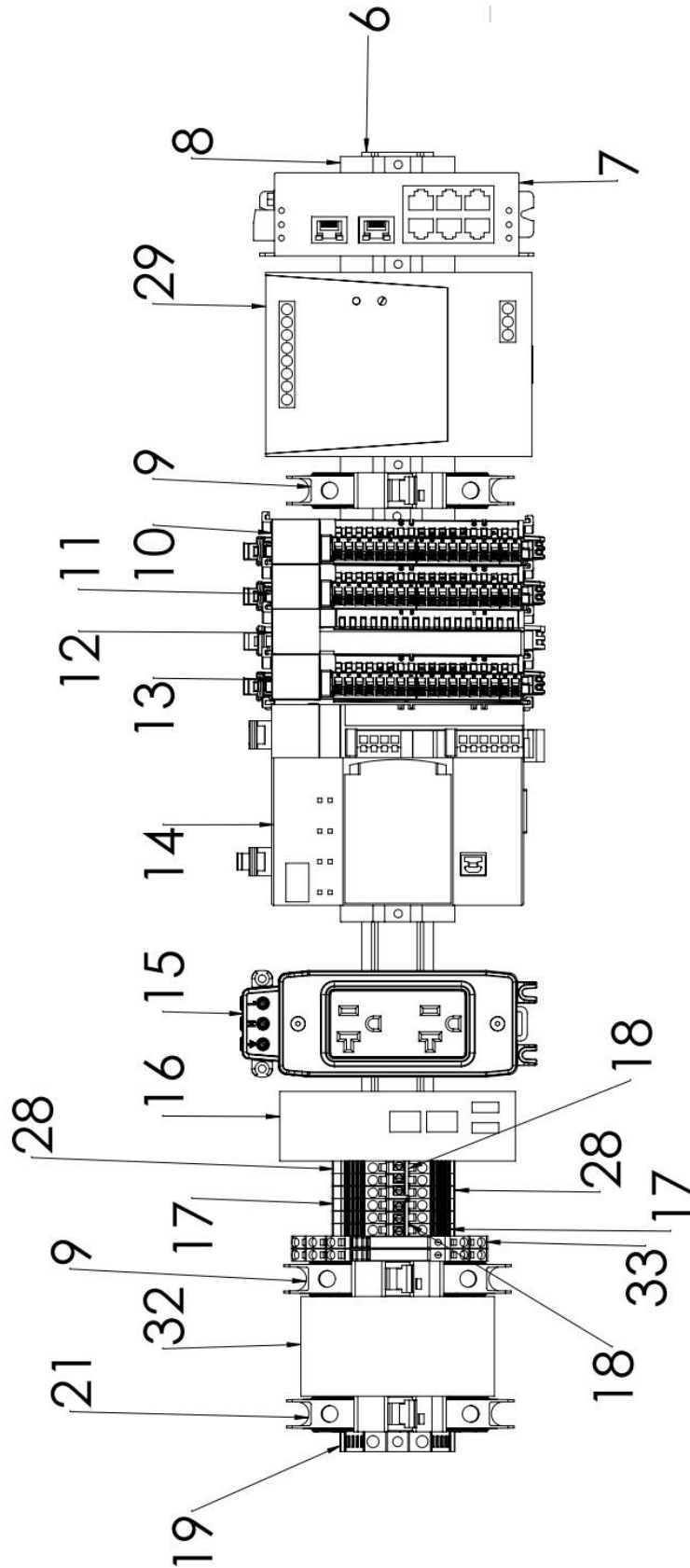



Low Voltage Panel Diagram (C)

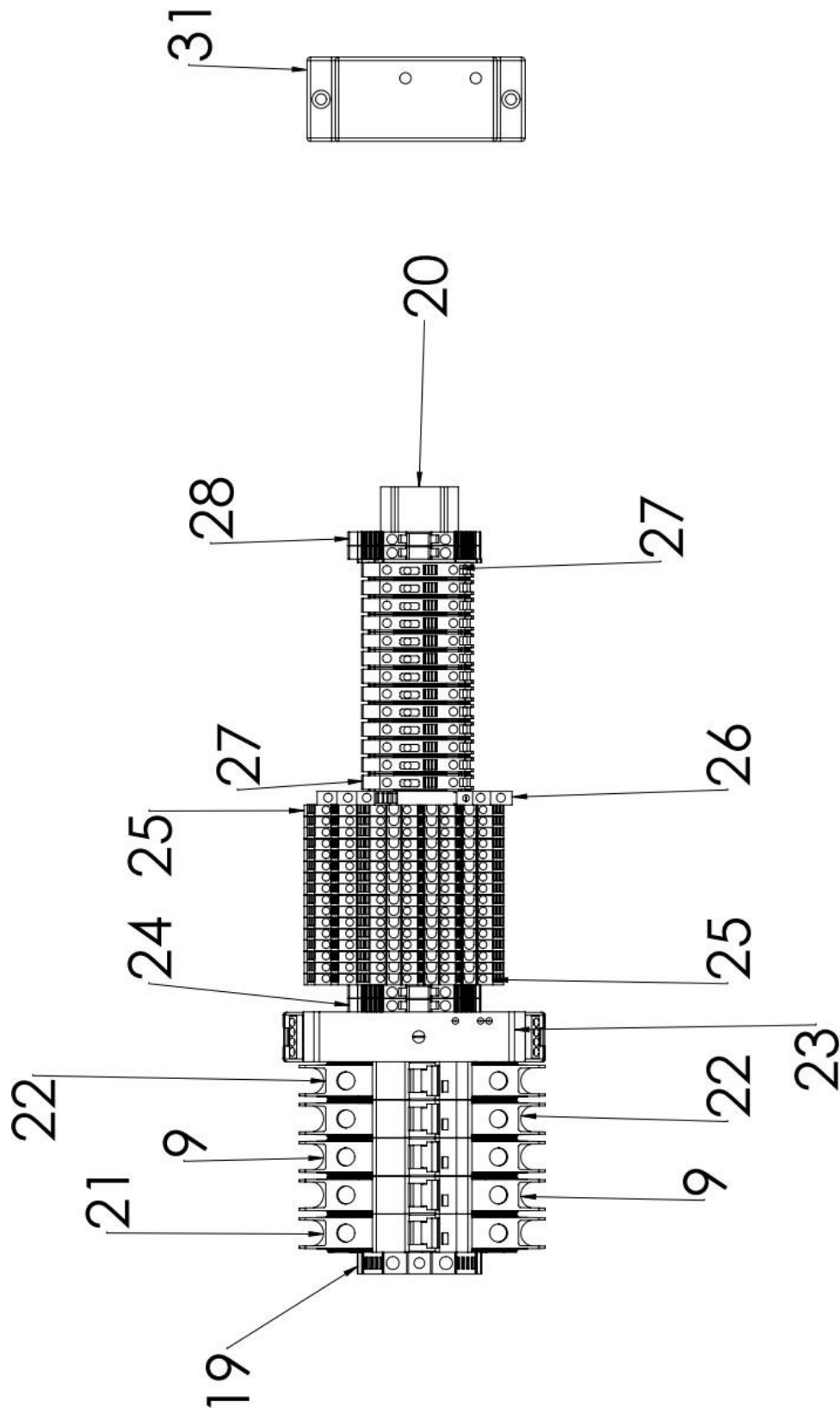

## Low Voltage Panel Parts List

Ref. No.	Part Description	Q'ty	Part No.	Part No. Factory Manual
1	24x42 Back Sheet	1	55KFW-E125	
2	4X38.5X2 PANDUIT	1	55KFW-E126	
3	4X18.5X1 PANDUIT	2	55KFW-E127	
4	4X26.5X1 PANDUIT	2	55KFW-E128	
5	H2omitter	1	55KFW-E7	
6	Din Rail 25in	1	55KFW-E129	
7	Ethernet Switch	1	55KFW-E130	
8	Terminal Block	5	55KFW-E90	
9	Circuit Breaker 5A	4	55KFW-E105	
10	Output Module	1	55KFW-E67	
11	RTD Input Card	1	55KFW-E30	
12	Digital Output Car	1	55KFW-E65	
13	Digital Input Card	1	55KFW-E28	
14	Enet Motion Controller	1	55KFW-E64	
15	Receptacle	1	55KFW-E115	
16	Onlogic PC	1	55KFW-E69	
17	Terminal Block	3	55KFW-E97	
18	Terminal Block	2	55KFW-E98	
19	Terminal Block	2	55KFW-E110	
20	Din Rail 14in	1	55KFW-E131	
21	Circuit Breaker 20A	2	55KFW-E93	
22	Circuit Breaker 1.6A	2	55KFW-E94	
23	Safety Relay	1	55KFW-E132	
24	Terminal Block	2	55KFW-E118	
25	Terminal Block	16	55KFW-E89	
26	Control Relay	1	55KFW-E107	
27	Terminal Block	13	55KFW-E133	
28	Terminal Block	5	55KFW-E96	
29	PS 480W 24V 20A	1	55KFW-E50	
30	Terminal Block	1	55KFW-E91	
31	DC Current Switch	1	55KFW-E88	
32	Control Line Conditioner	1	55KFW-E4	
33	Control Relay	2	55KFW-E107	

High Voltage Diagram (A)

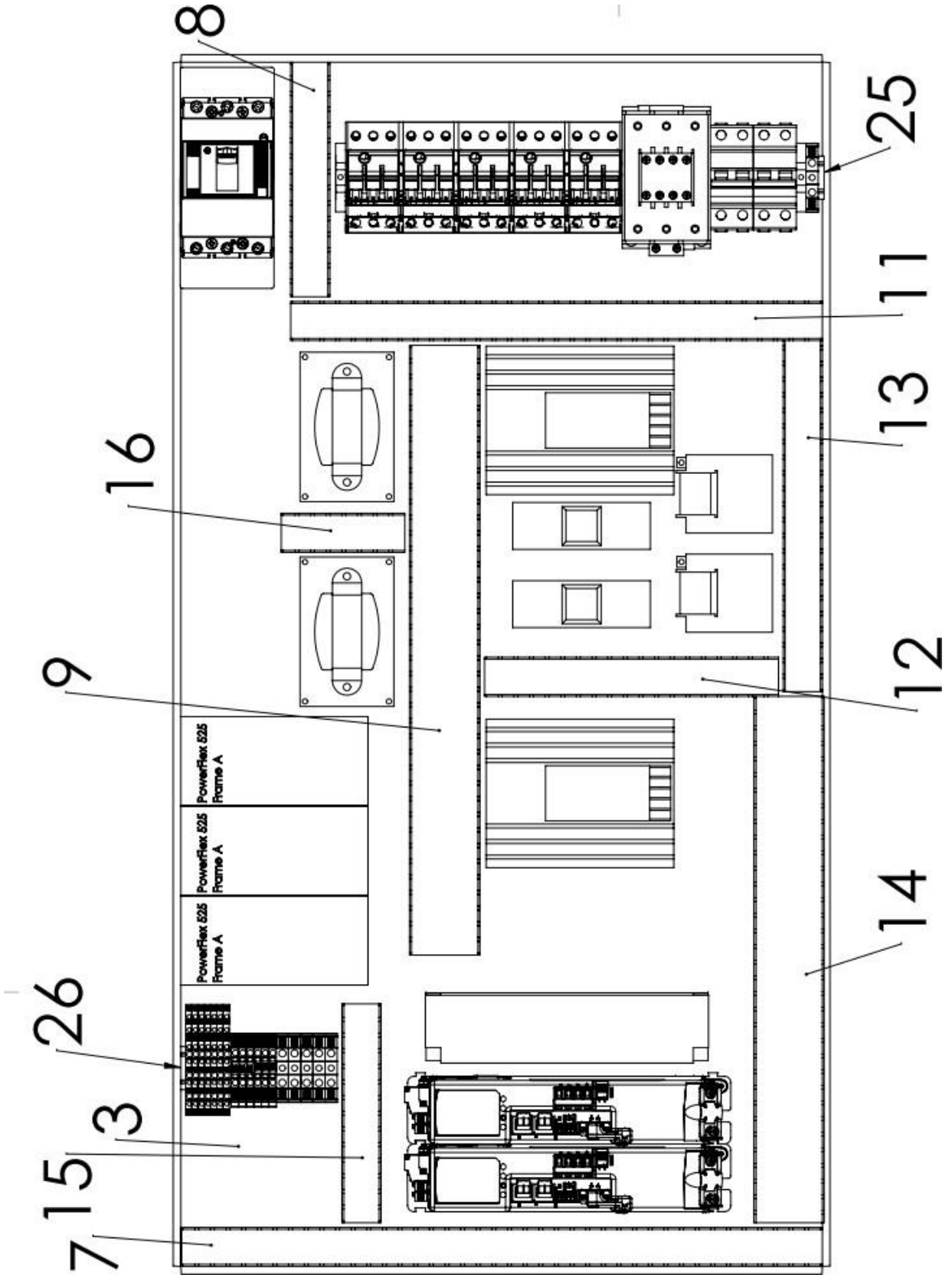



High Voltage Diagram (C)

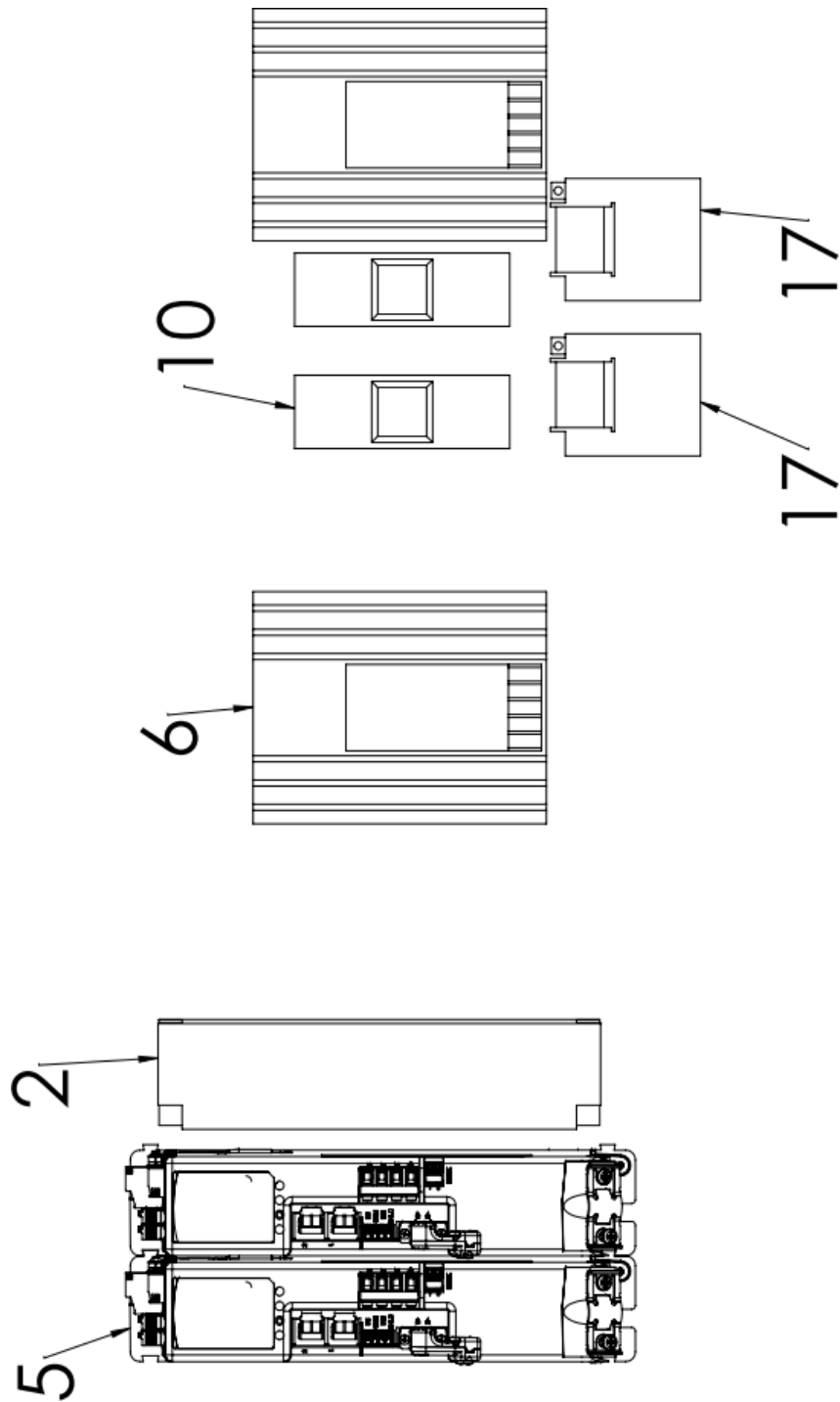

High Voltage Diagram (D)

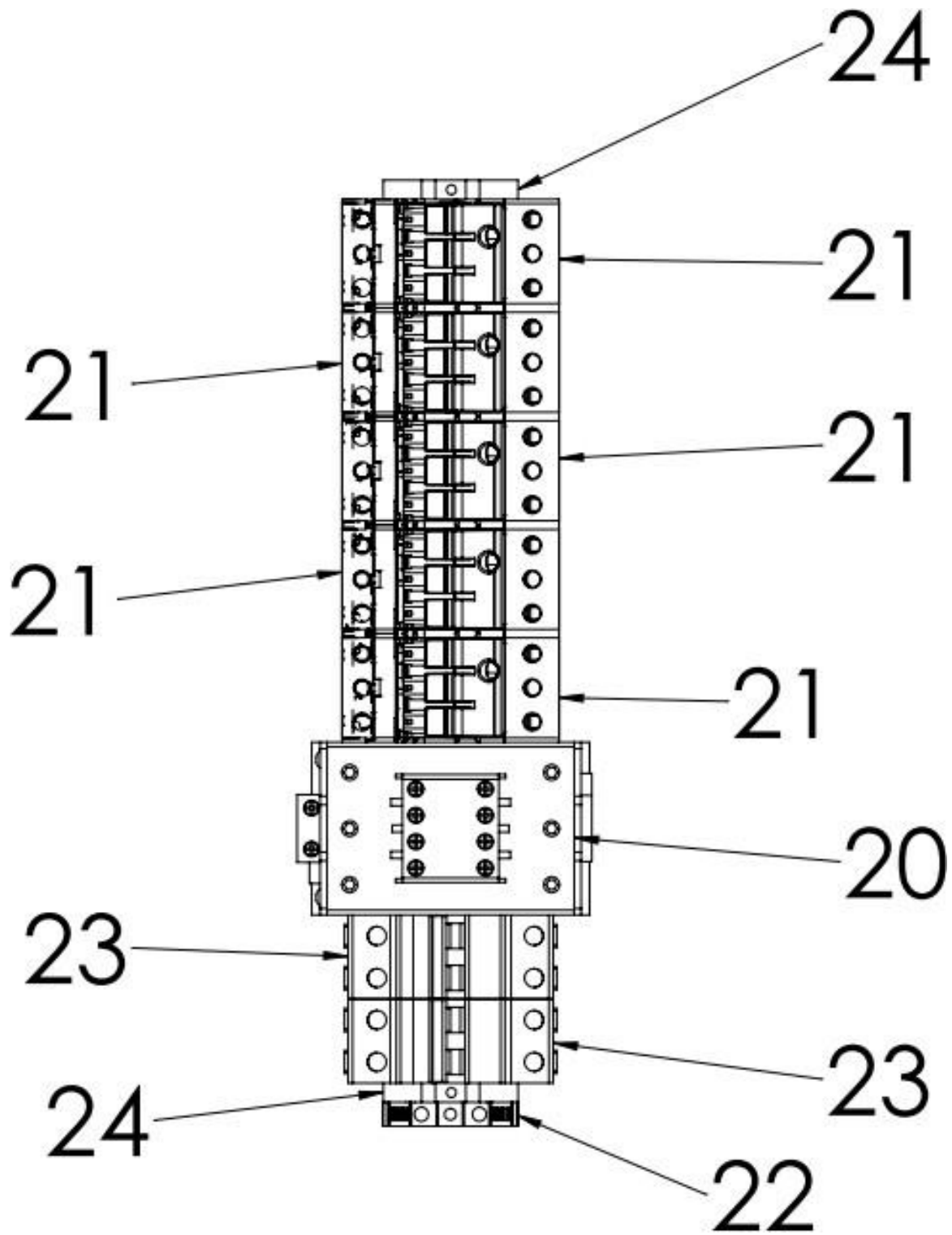

## High Voltage Parts List

Ref. No.	Part Description	Q'ty	Part No.	Part No. Factory Manual
1	Power Flex 525	3	55KFW-E36	
2	Line Filter	1	55KFW-E134	
3	23x42 Panel	1	55KFW-E125	
4	Molded Case Circuit Breaker	1	55KFW-E135	
5	Servo Drive	2	55KFW-E24	
6	Voltage Controller Watlow	2	55KFW-E71	
7	4x20.5x1 Panduit	1	55KFW-E136	
8	4x7.5x1 Panduit	1	55KFW-E137	
9	4x17x2 Panduit	1	55KFW-E138	
10	Watlow Fuse Block	2	55KFW-E147	
11	4x17x1 Panduit	1	55KFW-E139	
12	4x9.4x1 Panduit	1	55KFW-E140	
13	4x11.23x1 Panduit	1	55KFW-E141	
14	4x16.83x2 Panduit	1	55KFW-E142	
15	4x11x1 Panduit	1	55KFW-E143	
16	4x3.95x1 Panduit	1	55KFW-E144	
17	Current Limiting Circuit Board	2	55KFW-E148 (Discontinued)	
18	TX Transformer	2	55KFW-E149 (Discontinued)	
19	Transformer Plate	1	55KFW-E150 (Discontinued)	
20	Safety Contactor	1	55KFW-E34	
21	Fuse Holder	5	55KFW-E106	
22	Terminal Block	6	55KFW-E110	
23	Circuit Breaker 24A 2P	2	55KFW-E151	
24	Terminal Block	2	55KFW-E90	
25	DinRail 15.62	1	55KFW-E145	
26	DinRail 5	1	55KFW-E146	
27	Terminal Block	6	55KFW-E118	
28	Terminal Block End Barrier	1	55KFW-E91	
29	Terminal Block Jumper 3P	2	55KFW-E98	
30	3 Circuit Terminal Block	7	55KFW-E89	
31	Watlow 40 Amp Fuse	2	55KFW-E147-F	

## Sensors and Cables

Ref. No.	Part Description	Q'ty	Part No.	Part No. Factory Manual
	Anti Jam & End Regulation PE	2	55KFW-S-8	E3ZMT86
	PE Cables	4	55KFW-S-16	EVC003
	Home Prox Sensor	2	55KFW-S-17	IF5898

<b>Ref. No.</b>	<b>Part Description</b>	<b>Q'ty</b>	<b>Part No.</b>	<b>Part No. Factory Manual</b>
	Home Prox Cable	2	55KFW-S-18	EVC002
	Omega RTD	2	55KFW-S-19	RTDCAP-100A-2-P098-050-K-40
	90 Degree M12 to RJ45 Cable	1	55KFW-S-20	EVC933
	Encoder Power Cable	1	55KFW-S-21	EVS006